

**NEW!**

# 075 Autogas Pump

Designed for underground and aboveground tank applications

Pressure gauge connections help simplify analysis of system performance.

High strength metric fasteners.

Case and cover of ASTM A536 ductile iron, providing maximum thermal shock protection.

Self-aligning, free-floating, precision machined impeller, incorporating proprietary design, optimizes flow and provides quiet non-pulsating transfer of LPG.

Maximum sealing provided by a single balanced, precision lapped, mechanical seal.

Designed for ease of service. Seal can be replaced in minutes by simply removing the cover.

ANSI and DIN 300# flanges provide optimal leak control and enhances structural integrity.

Heavy-duty ball bearings are rated for continuous duty service and provide maximum life.

Three mounting options available: direct drive with coupling, belt drive, and direct mounted with C-face electric motor.

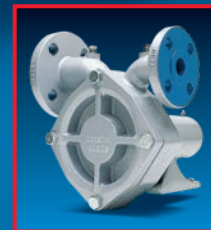

Frame Mount



Direct Mount

## A Cost Effective Alternative to Submersible Designs

### Meeting Global Demands for Autogas Applications...

In our continuous effort to meet the global demands by underground and aboveground tank applications, the 075 autogas series was designed for applications that require a lower flow rate and horsepower yet high differential pressure. The 075 is mounted above ground and is a great choice for single or dual hose applications.

### Continuous Duty Design...

Built for continuous duty service, the 075 autogas series incorporates heavy duty bearings, free floating impeller, a single mechanical seal, ANSI or DIN flange connections, metric fasteners, and a ductile iron case.

### Multiple Mounting Options...

The 075 autogas pump is available with two mounting options. You may select a frame mount for direct or belt drive configurations or a direct

mount that bolts to a standard C-Face 50 Hz (2880 RPM) or 60 Hz (3450 RPM) motor.

### Serviceability is Simple and Cost Effective...

Unlike submersible designs, the 075 is mounted aboveground so there is no need to disturb the piping. All parts are easily accessed by simply removing the pump head. This feature allows you to quickly service the pump on site and minimize costly downtime thereby making the 075 autogas pump a cost effective alternative to a submersible design.

### Applications:

- Autogas dispensing
- Cylinder filling
- Vaporizer feed
- Bulk transfer
- Direct burner feed

*Solutions beyond products...*

**CORKEN**  
IDEX

## Operating Specifications

Inlet: 1-1/2" ANSI 300# RF (DIN opt.)
Outlet: 1" ANSI 300# RF (DIN opt.)
RPM: 3450 @ 60 Hz, 2880 @ 50 Hz
Max. working pressure: 400 psig (27.6 bar)
Maximum driver: 20 hp (15 kW)
Max. differential pressure: 150 psig (10.3 bar)
Temperature range: -25° to 225°F (-32° to 107°C)
Flow range: 10–40 gpm (37.9 to 151.4 L/min)

## Performance Curves

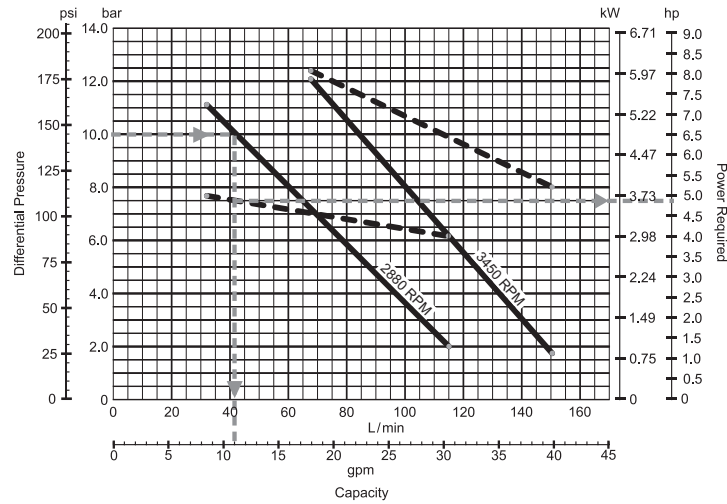

**2880 RPM @ 50 Hz**

**Differential pressure:**  
10.0 bar  
145.0 psi

**Flow:**  
42 L/min  
11 gpm

**Power required:**  
3.65 kW  
4.9 hp

**Curves based on LPG<sup>1</sup>**

Capacity ———  
Power required - - -

<sup>1</sup>The performance curves are based on aboveground LPG installations. Performance curves for underground LPG tanks will vary based on the specific installation. Consult factory.

## Material Specifications

Part	Standard Material	Optional Material
Case, cover	Ductile iron ASTM A536	
Impeller	Copper alloy ASTM B584, UNS C92300 (also known as Navy Bronze)	Steel Stainless steel
Impeller key	Steel, zinc plated	
Seal seat	Silicon carbide	
Seal rotor	Carbon	
Seal metal parts	Stainless steel	
Seal sleeve	Stainless steel	
Seal housing	Stainless steel	
Shaft	Steel	Stainless steel
Frame	FF/FD: Gray iron ASTM A48, Class 30 DLF/DLD: Ductile iron ASTM A536	
Bearing cap	Ductile iron	
O-rings	Buna-N	Neoprene <sup>®</sup> , Viton <sup>®</sup> , Buna-N, Kalrez <sup>®2</sup>
Retainer rings	Steel	
Bearings	Ball	

<sup>2</sup>Neoprene<sup>®</sup>, Viton<sup>®</sup> and Kalrez<sup>®</sup> are a registered trademarks of the DuPont company.

## Outline Dimensions

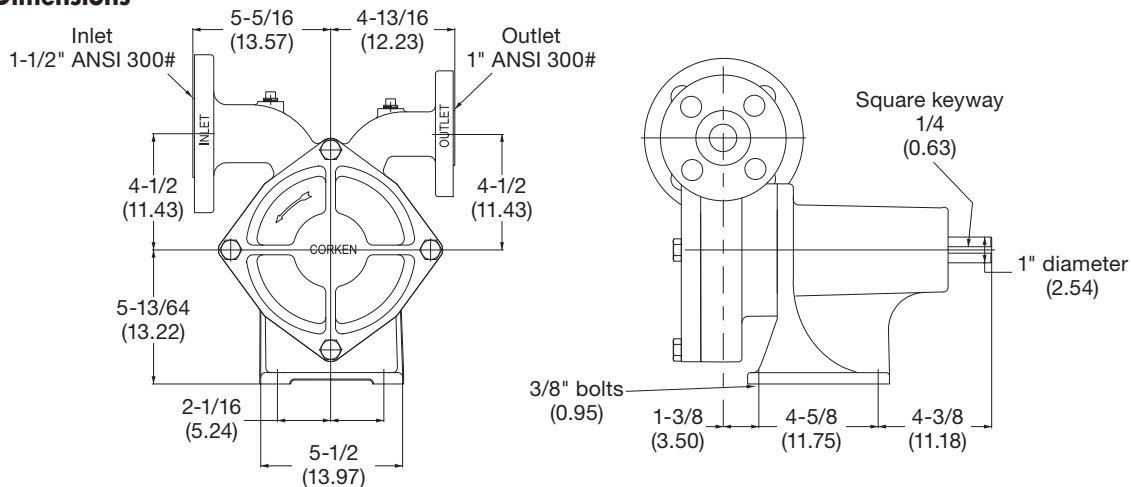

All dimensions are in inches (centimeters).

QUALITY  
**ISO 9001**  
SYSTEM

Solutions beyond products...  
**CORKEN**  
IDEX

ENVIRONMENTAL  
**ISO 14001**  
MANAGEMENT  
SYSTEM

Corken, Inc. • A Unit of IDEX Corporation  
9201 North I-35 Service Road, Oklahoma City, OK. 73131 U.S.A.  
Phone (405) 946-5576 • FAX (405) 948-7343

Visit our website at <http://www.corken.com> • E-mail us at [info.corken@idexcorp.com](mailto:info.corken@idexcorp.com)