

Installation, Operation & Maintenance Manual

Models B166 and T166 External Automatic Bypass Valves



*Model B166 External
Automatic Bypass Valve*



*Model T166 External
Automatic Bypass Valve*

Warning: (1) Periodic inspection and maintenance of Corken products is essential. (2) Inspection, maintenance and installation of Corken products must be made only by experienced, trained and qualified personnel. (3) Maintenance, use and installation of Corken products must comply with Corken instructions, applicable laws and safety standards (such as NFPA Pamphlet 58 for LP-Gas and ANSI K61.1-1972 for Anhydrous Ammonia). (4) Transfer of toxic, dangerous, flammable or explosive substances using Corken products is at user's risk and equipment should be operated only by qualified personnel according to applicable laws and safety standards.

Solutions beyond products...

CORKEN®

Warning

Install, use and maintain this equipment according to Corken's instructions and all applicable federal, state, local laws and codes. Periodic inspection and maintenance is essential.

Corken One Year Warranty

CORKEN, INC. warrants that its products will be free from defects in material and workmanship for a period of one year from date of installation, provided that the warranty shall not extend beyond twenty-four (24) months from the date of shipment from CORKEN. If a warranty dispute occurs, the DISTRIBUTOR may be required to provide CORKEN with proof of date of sale. The minimum requirement would be a copy of the DISTRIBUTOR'S invoice to the customer.

CORKEN products which fail within the warrant period due to defects in material or workmanship will be repaired or replaced at CORKEN's option, when returned, freight prepaid to CORKEN, INC., 9201 North I-35 Service Road, Oklahoma City, OK. 73131.

Parts subject to wear or abuse, such as mechanical seals, blades, piston rings, valves and packing, and other parts showing signs of abuse, neglect or failure to be properly maintained are not covered by this limited warranty. Also, equipment, parts and accessories not manufactured by CORKEN but furnished with CORKEN products are not covered by this limited warranty and the purchaser must look to the original manufacturer's warranty, if any. This limited warranty is void if the CORKEN product has been altered or repaired without the consent of CORKEN.

All implied warranties, including any implied warranty of merchantability or fitness for a particular purpose, are expressly negated to the extent permitted by law and shall in no event extend beyond the expressed warrantee period.

CORKEN DISCLAIMS ANY LIABILITY FOR CONSEQUENTIAL DAMAGES DUE TO BREACH OF ANY WRITTEN OR IMPLIED WARRANTY ON CORKEN PRODUCTS. Transfer of toxic, dangerous, flammable or explosive substances using CORKEN products is at the user's risk. Experienced, trained personnel in compliance with governmental and industrial safety standards should handle such substances.

Contacting the Factory

Before you contact the factory, note the model number and serial number of your pump. The serial number directs us to a file containing all information on material specifications and test data applying to your specific pump. When ordering parts, the Corken service manual or Operations, Installation and Maintenance (IOM) manual should be consulted for the proper part numbers. ALWAYS INCLUDE THE MODEL NUMBER AND SERIAL NUMBER WHEN ORDERING PARTS.

The model and serial numbers are shown on the nameplate of the unit. Record this information for future reference.

Model No. _____

Serial No. _____

Date Purchased _____

Date Installed _____

Purchased From _____

Installed By _____

Table of Contents

APPLICABLE NOTICES FOR ATEX 2014/34/EU CONFORMITY	4
FEATURES OF THE B166 EXTERNAL AUTOMATIC BYPASS VALVE	5
CHAPTER 1—INSTALLATION OF THE B166 EXTERNAL AUTOMATIC BYPASS VALVE	5
1.1 Operation of the B166 External Automatic Bypass Valve.	5
FEATURES OF THE T166 AUTOMATIC EXTERNAL BYPASS VALVE	7
CHAPTER 2—INSTALLATION OF THE T166 AUTOMATIC EXTERNAL BYPASS VALVE	7
2.1 Operation of the T166 Automatic External Bypass Valve.	7
APPENDICES	
A. Model Number Identification Code and Available Options	9
B. Specifications	10
C. Performance	10
D. Outline Dimensions	11
E. Parts Details	13

Applicable Notices for ATEX 2014/34/EU Conformity

Product Type:

Corken Liquid Transfer Bypass Valves

Model Covered:

T166 ONLY

Intended Application:

The bypass valve models covered by this manual conform to the European Union ATEX 2014/34/EU Directive for explosive gas atmospheres and transfer of liquefied gases such as Liquefied Petroleum Gas, anhydrous ammonia, freons, etc.

Possible Misuse Warning:

The designated bypass valve models must only be installed in systems designed for its intended use, similar to the examples presented in this manual.

ATEX Classification:

Group II; Category 2; G; Temperature Class T4 – T5

These products are classified under the ATEX directive as Equipment – Group II – Category 2 – equipment is intended for use in areas where explosive atmospheres caused by gases or vapors (G) may be present. The surface Temperature Class rating is a range between T4 275°F (135°C) and T5 212°F (100°C).

Nameplate:

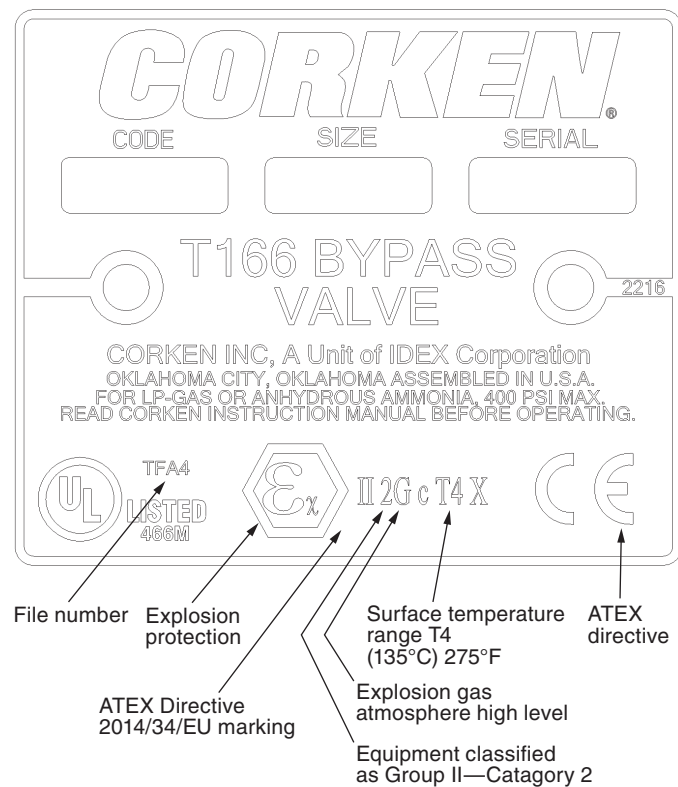

Training Instructions:

Instructions for the safe application and use of this product are provided in this manual. Read this manual completely prior to installation and use of this product. Only qualified and properly trained personnel should be allowed to install, operate, and maintain this equipment.

Mechanical Ignition Sources:

The bypass valve is installed as part of an assembly including the pump and the entire system must be grounded to prevent possible electrostatic discharge. Installation and adjustment guidelines are provided in this manual and are to be followed for the proper operation and performance of the valve.

Sound Levels:

These products are reactionary devices used in pumping systems. Sound levels are highly dependent upon the application, product being pumped, and installation. When operating in the system the valves should have a noise level no higher than 80 dBA.

Piping Forces and Moments:

Maximum Allowable Nozzle Forces and Moments

Note: Piping systems should be designed according to standard engineering practice and applicable national and local codes. NO piping induced forces or moments are recommended for Corken T166 bypass valves.

X—Horizontal (perpendicular to valve discharge port)

Y—Vertical

Z—Horizontal (parallel to valve discharge port)

$F_x = F_y = F_z = 42 \text{ lb (19 kg)}$

$M_x = M_y = M_z = 70 \text{ ft}\cdot\text{lb (10 kg}\cdot\text{m)}$

! Notice!

Corken bypass valves should only be installed in LPG & NH₃ systems that have been designed by qualified engineering personnel and operated and maintained by qualified technicians. The system must conform to all applicable local and national regulations and safety standards (specifically, LPG systems **must** conform to NFPA 58). This manual **must** be kept with the bypass valves and be reviewed **before** installing, operating or performing any maintenance work.

! Warning!

Do not attempt to open the pump or bypass valve until you have bled off the pressure. High pressure in the system can cause personal injury and/or property damage. Please note: if the system contains a meter, the differential valve will keep liquid under pressure in the pump, meter and piping even after the hose has been emptied.

Features of the B166 External Automatic Bypass Valve

The CORKEN B166 external bypass valve is a patented, dual purpose, automatic priming and differential valve designed for high-pressure volatile liquid service. This valve may be used with stable liquids as well.

The B166 external bypass valve was also designed to work in conjunction with CORKEN's Coro-Flo® regenerative turbine pumps but may be used with centrifugal pumps and others as well.

To ensure optimum performance of the external bypass valve and the entire pumping system, follow the instructions in this manual.

Chapter 1—Installation of the B166 External Automatic Bypass Valve

Proper installation of the CORKEN B166 external bypass valve ensures optimum performance of the pump and external bypass valve. Install the B166 external bypass valve on the discharge side of the pump in either a vertical or horizontal position. All CORKEN Coro-Flo® turbine pumps have a 3/4" NPT opening in the discharge nozzle for piping this valve. When using other pump designs without a 3/4" NPT opening, a tee must be installed in the discharge line. The discharge piping of the bypass valve should connect to the vapor section of the supply tank using an excess flow valve and **not a back check valve. Do not connect the outlet piping of the external bypass valve to the inlet piping of the pump.** A typical installation is shown in Figure 1.1. The recommended pipe sizes for discharge lines are given in the table below. For distances of 50 feet or more, the next larger pipe size should be used.

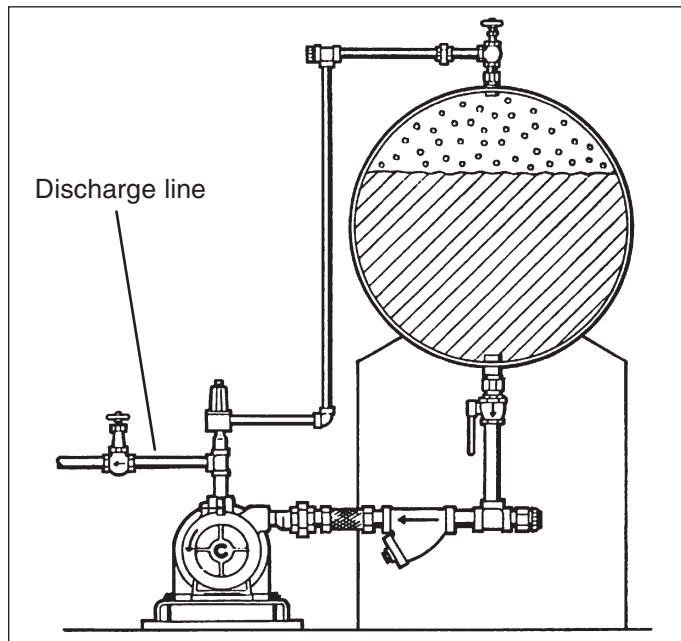

Figure 1.1: Typical installation.

Pipe Sizes for Discharge Line

Flow Rate	Pipe Size by Model Number	
	B166B-.75	B166B-.1
Up to 30 GPM	3/4"	—
Up to 40 GPM	—	1"

1.1 Operation of the B166 External Automatic Bypass Valve

Stationary Applications:

The differential pressure setting of the B166 external bypass valve is adjustable. The range of differential pressure depends on the size of the spring installed in the bypass valve. When the bypass valve ships from the CORKEN factory, a tag identifying the spring size is attached to the valve bonnet. The table below shows the part number and differential pressure range for each spring. All of the springs are interchangeable with each valve size.

Valve Model	Spring Number	Differential Pressure (PSIG)
B166	1138	25–60
	1193	50–150
	1193	100–225
	1313	

After the external bypass valve has been installed, it must be set properly.

1. Install liquid-filled pressure gauges equipped with a needle valve or snubber in the following locations:
 - a. Pump discharge gauge port or inlet side of the bypass valve.
 - b. Supply tank and/or pump suction.
2. Attach an ammeter to a motor lead of the electric motor.

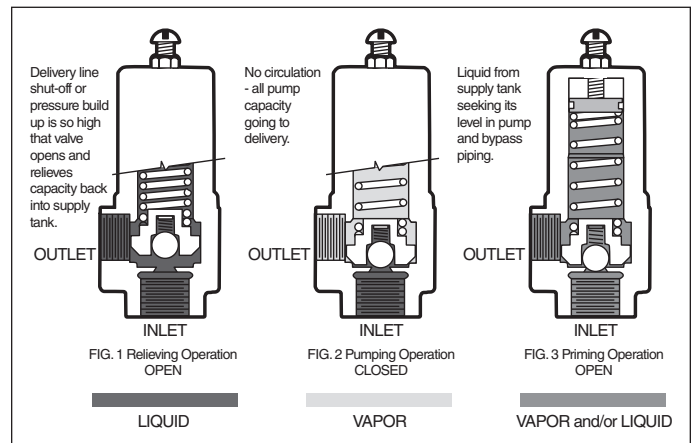

Figure 1.2: B166 with priming function.

-
3. Loosen the locknut on the B166 external bypass valve and **decrease** the pressure to the lowest setting by turning the adjusting screw **counterclockwise** until spring tension is no longer present.
 4. Make sure the shut-off valves on pump discharge line and bypass return line are in a fully open position.
 5. Record the pressure indicated on the gauge mounted to the 1/4" NPT discharge opening of the pump.
 6. Fully open the outlet valve of the supply tank. Start pumping at a normal delivery rate and circulate the liquid back to the supply tank using the discharge line.
 7. Slowly close the shut-off valve located on pump discharge line so all of the liquid flows through the B166 external bypass valve. Record the pressure indicated on the gauge mounted to the 1/4" NPT discharge opening of the pump.
 8. Slowly **increase** the pressure setting of the B166 bypass valve by turning the adjusting screw **clockwise** and watch the pressure gauge. When the pressure stops increasing or just before it drops back to the starting pressure, record the highest pressure indicated on the gauge mounted to the 1/4" NPT discharge opening of the pump and turn off the pump.
 9. **Decrease** the pressure setting of the B166 external bypass valve again by turning the adjusting screw **counterclockwise** two to three turns.
 10. Re-start the pump and **increase** the pressure setting of the B166 external bypass valve by turning the adjusting screw **clockwise**. The final pressure setting should be 5–10 psi (0.3–0.69 bar) under the pressure indicated in step 8 listed above; however, depending on your pump model, the final pressure should not exceed 100–125 psi (6.9–8.6 bar) higher than the starting pressure.
11. Once a satisfactory pressure adjustment has been achieved, attach the “tamper-proof” seal furnished with the B166 external bypass valve to prevent unauthorized adjustments.
 12. Open the shut-off valve located on the pump discharge line downstream of the B166 external bypass valve and continue pumping as needed.

WARNING: Do not adjust the external bypass valve beyond the range of the spring being used.

NOTE: On Anhydrous Ammonia and LP-Gas installations, follow the guidelines provided by Underwriter’s Laboratories, Inc. and NFPA Pamphlet # 58.

 **Notice!**

1. If the automatic external bypass valve is sized and set correctly, the manual or hand operated bypass valve—if applicable—should remain in the closed position during normal operation. Keeping the manual or hand operated bypass valve closed ensures the automatic external bypass valve functions in normal operations.
2. Annual inspection and testing of the pump’s internal relief valve—if applicable—and the automatic external bypass valve are recommended. For testing procedures refer to the adjustment procedures listed in this manual.

EXAMPLE: The starting pressure is 125 psi (8.6 bar). After starting the pump it increases to 150 psi (10.3 bar) and adjusts to a maximum pressure of 235 psi (16.2 bar) before dropping back to the starting pressure of 125 psi (8.6 bar). Since the final pressure setting should be 5–10 psi (0.3–0.69 bar) below the maximum pressure of 235 psi (16.2 bar), the bypass should be set at 225–230 psi (15.5–15.9 bar) and locked in position using the locknut.

NOTE: This may be higher than the **full load amperage** (FLA) or **service factor amperage** (SFA) of the motor. If the pump operates in a continuous duty application, the final pressure setting of the external bypass should be set just below the FLA or SFA.

Features of the T166 Automatic External Bypass Valve

The CORKEN T166 external bypass valve is designed for use with truck pumps. It controls the pump discharge pressure and bypasses excess liquid back to the truck tank.

This bypass valve can also be used in stationary applications utilizing sliding vane pumps.

Chapter 2—Installation of the T166 Automatic External Bypass Valve

Proper installation ensures optimum performance of the pump and external bypass valve. Install the T166 external bypass valve on the discharge side of the pump in either a vertical or horizontal position. The discharge piping of the bypass valve typically connects to the vapor section of the truck tank using a back check valve. A typical truck installation is shown in Figure 2.1. The recommended pipe size for the discharge line is given in the table below. For distances of 50 feet or more, the next larger pipe size should be used.

Stationary applications with internal relief valves: When the T166 external bypass valve is used for vapor venting, the piping should be the same size used with the B166 external bypass valve.

To ensure optimum performance of the external bypass valve and the entire pumping system, follow the instructions in this manual.

Pipe Size for the Discharge Line

Flow Rate	Pipe Size by Model Number	
	T166-1.25	T166-1.5
Up to 80 GPM	1-1/4"	—
Up to 100 GPM	—	1-1/2"

2.1 Operation of the T166 Automatic External Bypass Valve

Truck Applications:

The differential pressure setting of the B166 external bypass valve is adjustable. The range of differential pressure depends on the size of the spring installed in the bypass valve. When the bypass valve ships from the CORKEN factory, a tag identifying the spring size is attached to the valve bonnet. The table below shows the part number and differential pressure range for each spring. All of the springs are interchangeable with each valve size.

Valve Model	Spring Number	Differential Pressure (PSIG)
T166	1138	25–60
	1193	50–150
	1193	100–225
	1313	

1. Install liquid-filled pressure gauges equipped with a needle valve or snubber in the following locations:
 - a. Pump discharge gauge port or Inlet side of the bypass valve.
 - b. Supply tank and/or pump suction.

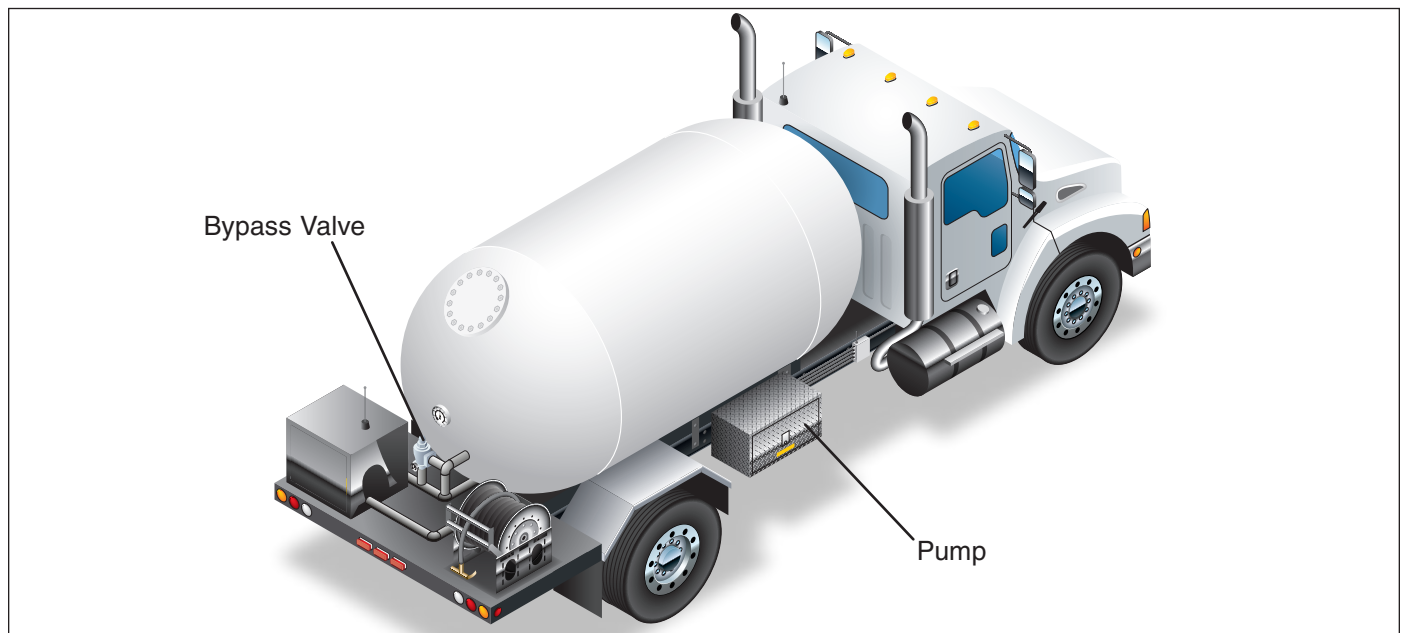

Figure 2.1: Typical installation.

-
2. Connect the delivery hose to the receiving/storage tank or delivery tank port for recirculation.
 3. All shut-off valves on the pump discharge line and bypass return line should be in a fully open position.
 4. Fully open the outlet valve of the supply tank and start pumping at a normal delivery rate. Make sure the direction of the rotating shaft follows the directional arrow located on the pump casing.
 5. If the pump has an internal relief valve, check the pressure setting by slowly closing the shut-off valve in the bypass return line.
 6. Slowly close the shut-off valve located on the pump's discharge line while observing the pressure gauge on the pump's discharge port. As the internal relief valve begins to open, the differential pressure typically drops. It is important to record the peak differential pressure (the difference between inlet and outlet pressure) before the internal relief valve opens. After circulation starts to flow through the internal relief valve, the pressure will drop significantly due to vaporization.

NOTE: The internal relief valve on the Z-Series truck pumps is pre-set at the factory and not adjustable in the field.
 7. After the setting of the internal relief valve is confirmed, open the shut-off valves located on the pump discharge line and the bypass return line and resume normal operation of the pump.
 8. To confirm the setting for the T166 external bypass valve, slowly close the shut-off valve in the pump's discharge line and record the pressure shown on the gauge. The difference between the pump's discharge pressure and the tank pressure (before pumping) is the setting of the external bypass valve.
 9. If the pump is equipped with an internal relief valve, the T166 external bypass valve should be set 20–25 psi (1.38 to 1.72 bar) below the setting of the pump's internal relief valve. Following this guideline ensures the liquid does not recirculate through the internal relief valve and eliminates the possibility of erratic "hunting" between the two valves.
 10. Reopen the shut-off valve in the pump's discharge line and resume normal operation of the pump. Record the pressure shown on the gauge. The difference between the pump's discharge pressure and the tank pressure (before pumping) is the normal operating pressure of the system.
 11. If possible, the setting of the T166 external bypass valve should be 15 psi (1.03 bar) higher than the normal operating pressure of the piping system. An operating pressure near the external bypass valve setting may cause the liquid to recirculate unnecessarily.
 12. Adjust the pressure setting of the T166 external bypass valve if necessary. The external bypass valve can be adjusted by loosening the locknut and turning the adjusting screw.
 - a. To **increase** the pressure setting, loosen the locknut and turn the adjusting screw **clockwise**.
 - b. To **decrease** the pressure setting, loosen the locknut and turn the adjusting screw **counterclockwise**.
 13. Once a satisfactory pressure adjustment has been achieved, attach the "tamper-proof" seal furnished with the external bypass valve to prevent unauthorized adjustments.

 **Notice!**

1. If the external automatic bypass valve is sized and set correctly, a manual or hand operated bypass valve—if applicable—should remain in the closed position during normal operation. Keeping the manual or hand operated bypass valve closed ensures the external automatic bypass valve operates in a normal capacity.
2. Annual inspection and testing of the internal relief valve—if applicable—and the external automatic bypass valve are recommended. For testing procedures refer to the adjustment procedures listed in this manual.

Appendix A—B166 and T166 Model Number and Identification Code

Base Model	B166B-.75	B166B-1	T166-1.25	T166-1.5
Inlet	3/4" NPT	1" NPT	1-1/4" ANSI	1-1/2" ANSI
Outlet	3/4" NPT	1" NPT	1-1/4" ANSI	1-1/2" ANSI
Maximum flow rate (gpm)	30	40	80	100
Ship weight lb (kg)	9 (4.1)	9 (4.1)	9 (4.1)	9 (4.1)

Model Number
Base X X X

Springs	25–60 psig differential range	No charge option	A
	50–150 psig differential range	No charge option	B
	100–225 psig differential range	No charge option	C

O-ring Material	Buna-N	Standard	A
	Neoprene ^{®1}	No charge option	B
	Viton ^{®1}	No charge option	D
	Ethylene propylene	No charge option	G
	Kalrez ^{®1}	No charge option	K

Flanges	Threaded body, no flanges	Standard	U
---------	---------------------------	----------	---

¹Registered trademark of the DuPont company.

Appendix B—Specifications

Equipment Type

B166	Combination bypass and priming valve Flows up to 40 gpm (9.1 m ³ /hr)
T166	High pressure build-up valve Flows are 30 to 100 gpm (6.8 to 22.7 m ³ /hr)

Applications

B166	Used with small cylinder filling pumps and aerosol propellant feed pumps.
T166	Used with truck pumps and multi cylinder filling pumps.

Features & Benefits

B166	Patented vapor recovery system keeps the pump primed at all times and minimizes wear.
T166	Opens gradually as the pressure builds up to modulate the flow. Continuous internal bleed assists in eliminating vapors.

Operating Specifications

Specification	B166	T166
Inlet	3/4", 1"	1-1/4", 1-1/2"
Outlet	3/4", 1"	1-1/4", 1-1/2"
Differential pressure range psi (bar)	25–225 (1.7–15.5)	25–225 (1.7–15.5)

Material Specifications

Part	Model	Standard Material	Optional Material
Valve body	B166, T166	Ductile iron: ASTM 536, 60-40-18	
Valve bonnet	B166, T166	Ductile iron: ASTM 536, 60-40-18	
O-rings	B166, T166	Buna-N	Neoprene ^{®1} , Viton ^{®1} , Ethylene propylene, Kalrez ^{®1}
Spring	B166, T166	Music wire/chrome silicon	
Adjusting screw gasket	B166, T166	1010 hot rolled steel	
Spring guide	B166, T166	8620 A322 ASTM steel	
Relief Valve	B166, T166	17-4 PH stainless steel	

¹Registered trademark of the DuPont company.

Appendix C—Models B166 and T166 Performance Curves

B166 Performance Curve

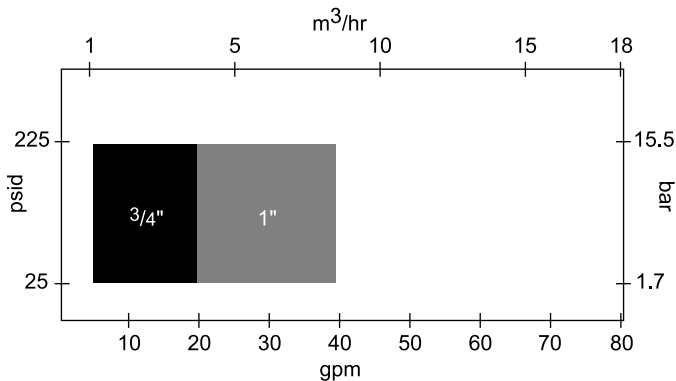

T166 Performance Curve

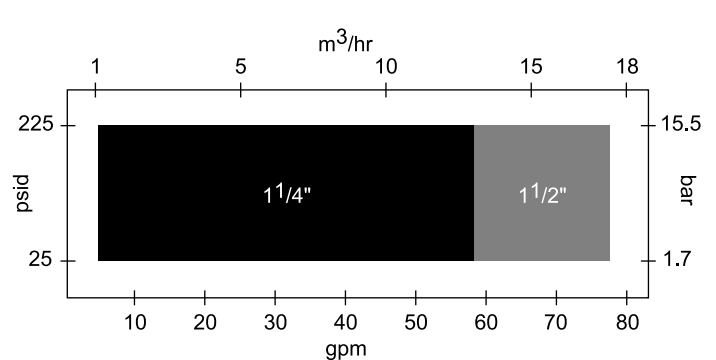

Appendix D—Outline Dimensions for Model B166

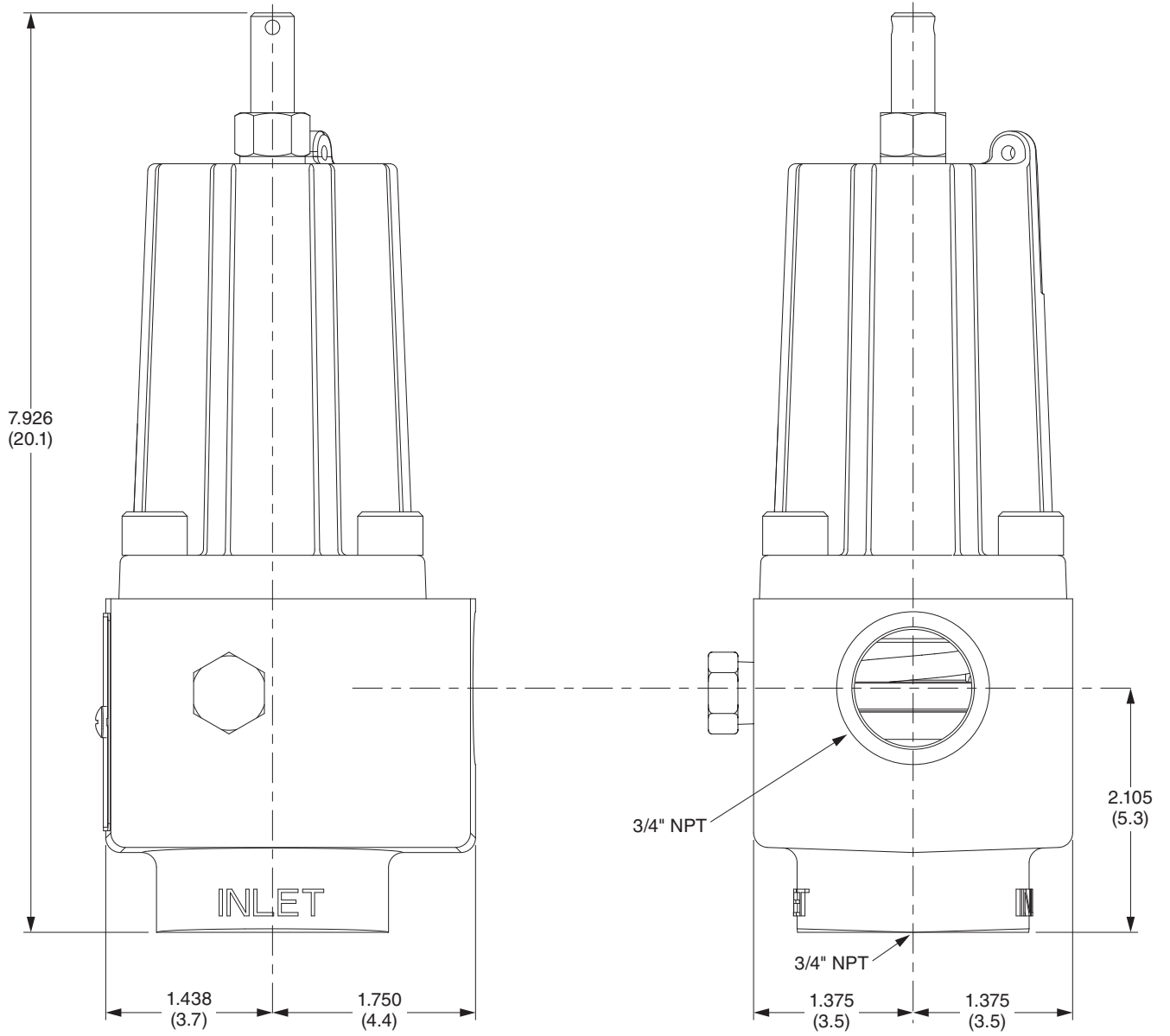

All dimensions are in inches (centimeters).

Appendix D—Outline Dimensions for Model T166

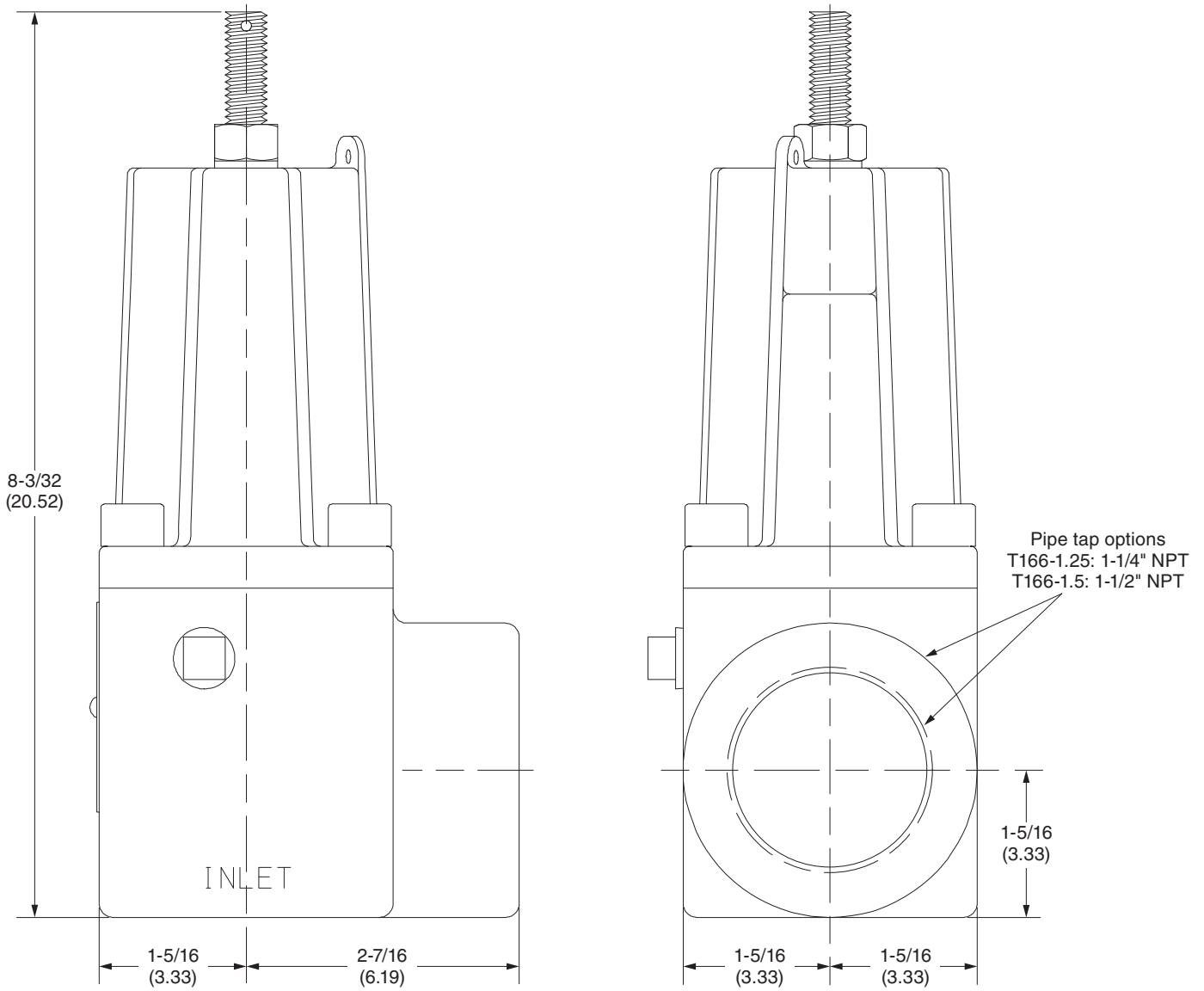

All dimensions are in inches (centimeters).

Appendix E—Parts Details for Models B166B-.75 and B166B-1

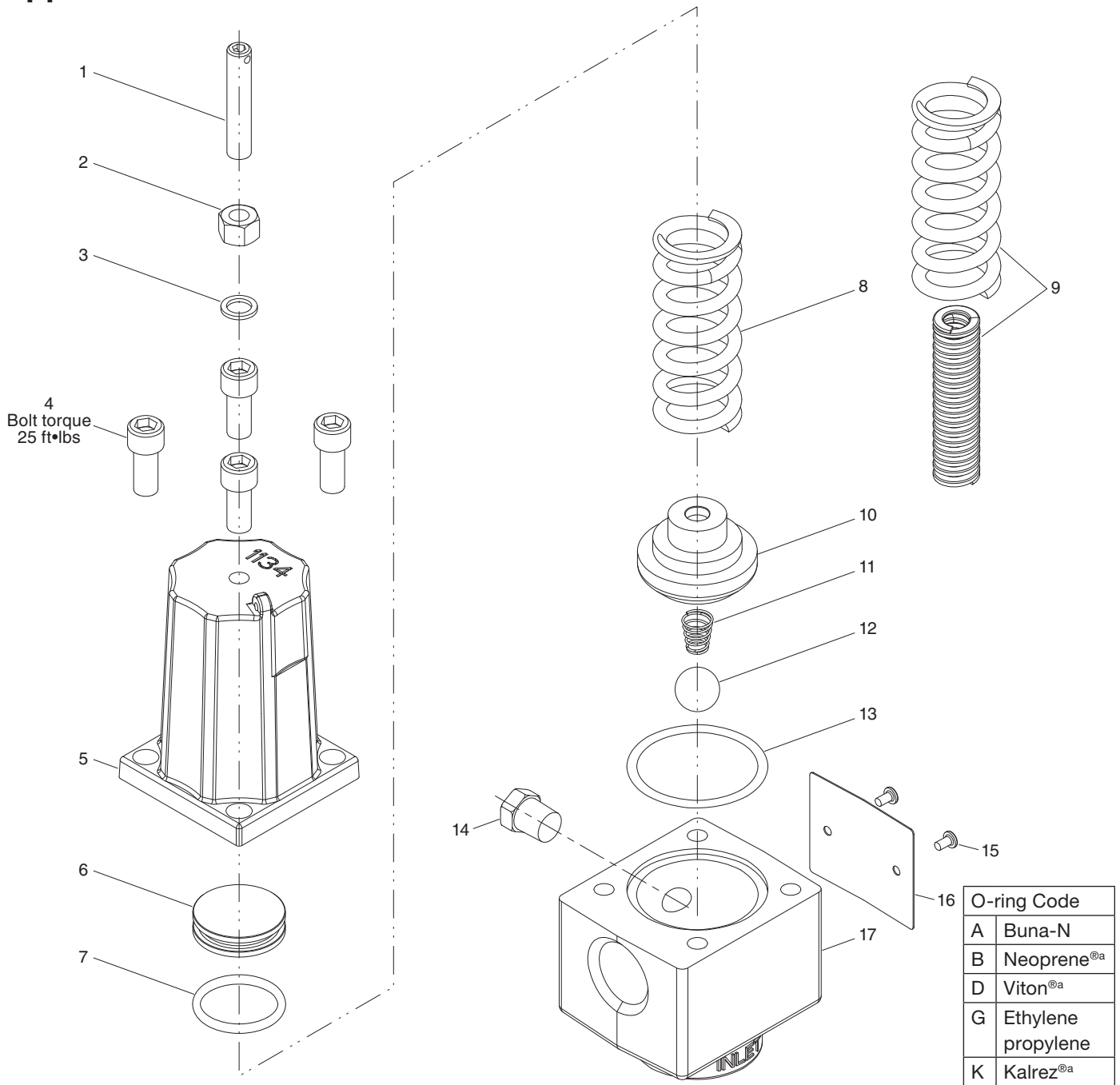

Ref. No.	Part No.	Description	Qty
1.	2911	Adjusting screw	1
2.	7101-037NC01A	Hex nut	1
3.	2732	Center head bolt gasket	1
4.	7002-037NC087A	Socket head bolt	4
5.	1134	Bonnet	1
6.	1136	Spring seal	1
7.	2-217 ^b	O-ring	1
8.	1138	Relief spring (25–60 psi)	1
	1193	Relief spring (50–150 psi)	1
9.	1193	Relief springs (100–225 psi)	1
	1313		1
10.	1251	Valve	1

Ref. No.	Part No.	Description	Qty
11.	1139	Ball spring (standard)	1
	2035 ^c	Ball spring (heavy duty)	
12.	1137	Ball	1
13.	2-224 ^b	O-ring	1
14.	3442	Pipe plug	1
15.	7012-006SF025C	Pan HD phillip 6-32 x 1/4"-Type F SS	2
16.	2030	Nameplate	1
17.	1200	3/4" Body (B166B-.75)	1
	1200-1	1" Body (B166B-1)	1

^aRegistered trademark of the DuPont company.

^b_ denotes O-ring code. See chart above.

^cUsed with relief springs 1193 and 1313 (100–225 psi).

Appendix E—Parts Details for Models T166-1.25 and T166-1.5"

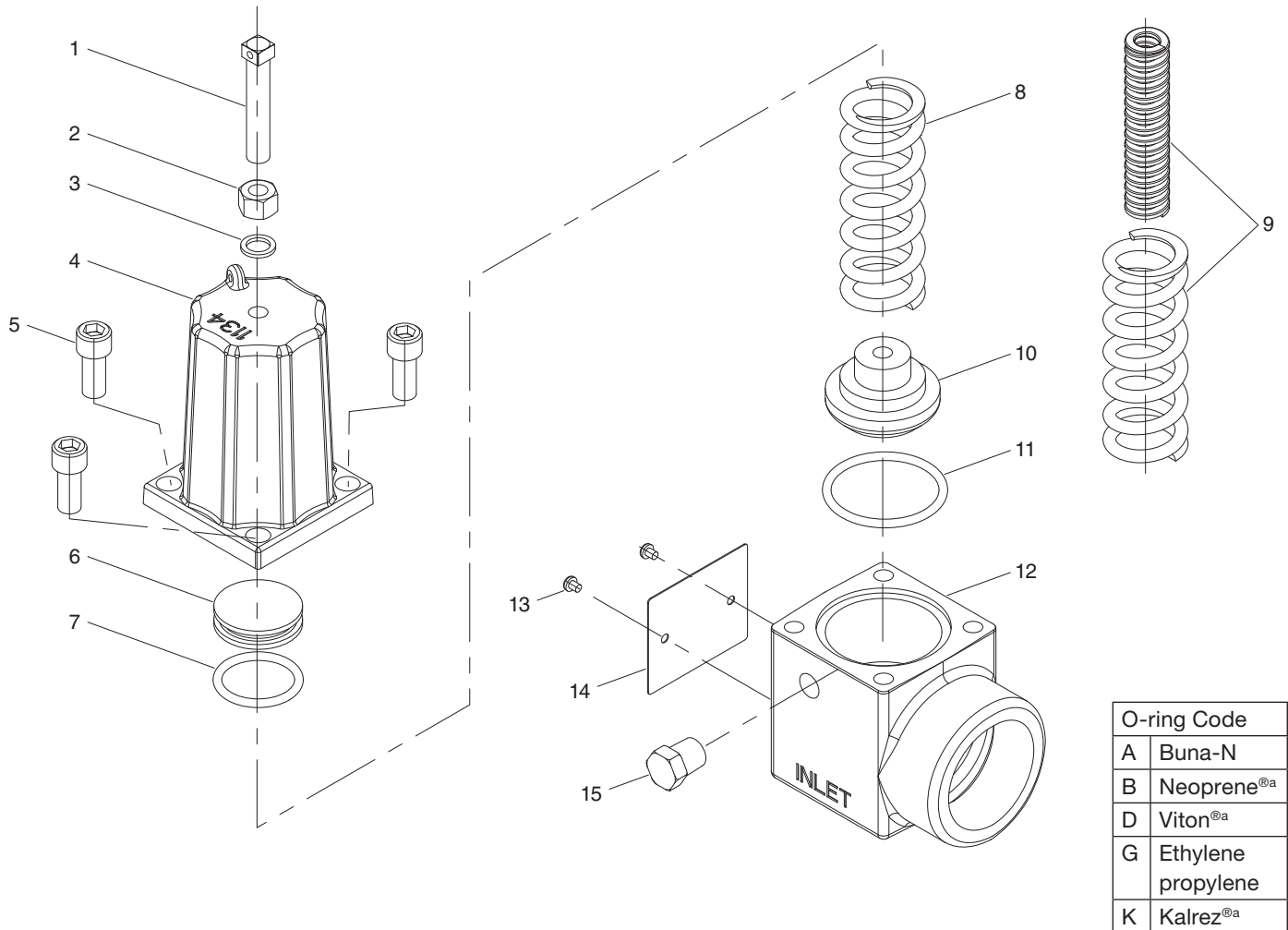

Ref. No.	Part No.	Description	Qty
1.	2911	Adjusting screw	1
2.	7101-037NC01A	Head head nut—3/8-16	1
3.	2732	Center headbolt gasket — Steel	1
4.	1134	Bonnet	1
5.	7002-037NC087A	Socket head—3/8-16 X 7/8", gr 8	4
6.	1136	Spring seal	1
7.	2-217 ^b	O-ring	1
8.	1138	Spring (25 to 60 psi)	1
	1193	Spring (50 to 150 psi)	1
9.	1193	Spring (100 to 225 psi)	1
	1313		1

Ref. No.	Part No.	Description	Qty
10.	2215	Valve	1
11.	2-224 ^b	O-ring	1
12.	1320-2	Body—T166-1-1/4"	1
	1320-3	Body—T166-1-1/2"	1
13.	7012-006SF019E	Pan head Phillip - 6-32 X3/16"-TYP	2
14.	2216	Nameplate	1
15.	3442	Pipe plug—1/4 NPT	1

^aRegistered trademark of the DuPont company.

^b_ denotes O-ring code. See chart above.

Solutions beyond products...

CORKEN®

CORKEN, INC. • A Unit of IDEX Corporation

9201 North I-35 Service Road, Oklahoma City, OK. 73131

Phone (405) 946-5576 • Fax (405) 948-7343

Visit our website at <http://www.corken.com>

or e-mail us at cocsalesdept@idexcorp.com

