

Installation, Operation & Maintenance Manual

Model ZV200 External Automatic Bypass Valve



Model ZV200 External
Automatic Bypass Valve

Warning: (1) Periodic inspection and maintenance of Corken products is essential. (2) Inspection, maintenance and installation of Corken products must be made only by experienced, trained and qualified personnel. (3) Maintenance, use and installation of Corken products must comply with Corken instructions, applicable laws and safety standards (such as NFPA Pamphlet 58 for LP-Gas and ANSI K61.1-1972 for Anhydrous Ammonia). (4) Transfer of toxic, dangerous, flammable or explosive substances using Corken products is at user's risk and equipment should be operated only by qualified personnel according to applicable laws and safety standards.

Solutions beyond products...

CORKEN®

Warning

Install, use and maintain this equipment according to Corken's instructions and all applicable federal, state, local laws and codes. Periodic inspection and maintenance is essential.

Corken One Year Warranty

CORKEN, INC. warrants that its products will be free from defects in material and workmanship for a period of one year from date of installation, provided that the warranty shall not extend beyond twenty-four (24) months from the date of shipment from CORKEN. If a warranty dispute occurs, the DISTRIBUTOR may be required to provide CORKEN with proof of date of sale. The minimum requirement would be a copy of the DISTRIBUTOR'S invoice to the customer.

CORKEN products which fail within the warrant period due to defects in material or workmanship will be repaired or replaced at CORKEN's option, when returned, freight prepaid to CORKEN, INC., 9201 North I-35 Service Road, Oklahoma City, OK. 73131.

Parts subject to wear or abuse, such as mechanical seals, blades, piston rings, valves and packing, and other parts showing signs of abuse, neglect or failure to be properly maintained are not covered by this limited warranty. Also, equipment, parts and accessories not manufactured by CORKEN but furnished with CORKEN products are not covered by this limited warranty and the purchaser must look to the original manufacturer's warranty, if any. This limited warranty is void if the CORKEN product has been altered or repaired without the consent of CORKEN.

All implied warranties, including any implied warranty of merchantability or fitness for a particular purpose, are expressly negated to the extent permitted by law and shall in no event extend beyond the expressed warrantee period.

CORKEN DISCLAIMS ANY LIABILITY FOR CONSEQUENTIAL DAMAGES DUE TO BREACH OF ANY WRITTEN OR IMPLIED WARRANTY ON CORKEN PRODUCTS. Transfer of toxic, dangerous, flammable or explosive substances using CORKEN products is at the user's risk. Experienced, trained personnel in compliance with governmental and industrial safety standards should handle such substances.

Contacting the Factory

Before you contact the factory, note the model number and serial number of your pump. The serial number directs us to a file containing all information on material specifications and test data applying to your specific pump. When ordering parts, the Corken service manual or Operations, Installation and Maintenance (IOM) manual should be consulted for the proper part numbers. ALWAYS INCLUDE THE MODEL NUMBER AND SERIAL NUMBER WHEN ORDERING PARTS.

The model and serial numbers are shown on the nameplate of the unit. Record this information for future reference.

Model No. _____

Serial No. _____

Date Purchased _____

Date Installed _____

Purchased From _____

Installed By _____

Table of Contents

APPLICABLE NOTICES FOR ATEX 2014/34/EU CONFORMITY	4
FEATURES OF THE ZV200 EXTERNAL AUTOMATIC BYPASS VALVE	5
INSTALLATION OF THE ZV200 EXTERNAL AUTOMATIC BYPASS VALVE	5
Operation of the ZV200 External Automatic Bypass Valve	5
APPENDICES	
A. Model Number Identification Code and Available Options	8
B. Specifications	9
C. Performance	9
D. Outline Dimensions	10
E. Parts Details	11
F. Troubleshooting Guide	12
G. Extended Storage	12

Applicable Notices for ATEX 2014/34/EU Conformity

Product Type:

Corken Liquid Transfer Bypass Valves

Model Covered:

ZV200

Intended Application:

The bypass valve models covered by this manual conform to the European Union ATEX 2014/34/EU Directive for explosive gas atmospheres and transfer of liquefied gases such as Liquefied Petroleum Gas, anhydrous ammonia, freons, etc.

Possible Misuse Warning:

The designated bypass valve models must only be installed in systems designed for its intended use, similar to the examples presented in this manual.

ATEX Classification:

Group II; Category 2; G; Temperature Class T4 – T5

These products are classified under the ATEX directive as Equipment – Group II – Category 2 – equipment is intended for use in areas where explosive atmospheres caused by gases or vapors (G) may be present. The surface Temperature Class rating is a range between T4 275°F (135°C) and T5 212°F (100°C).

Nameplate:

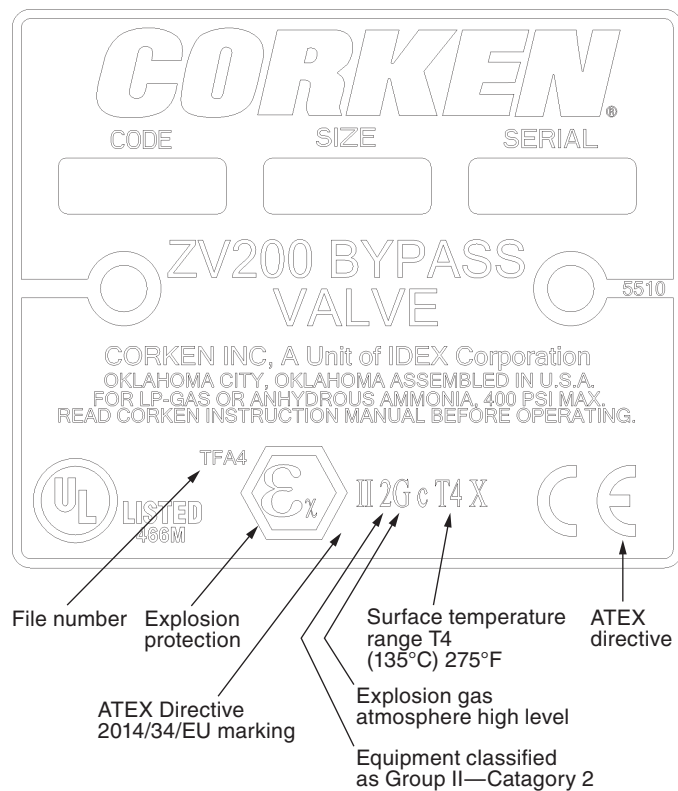

Training Instructions:

Instructions for the safe application and use of this product are provided in this manual. Read this manual completely prior to installation and use of this product. Only qualified and properly trained personnel should be allowed to install, operate, and maintain this equipment.

Mechanical Ignition Sources:

The bypass valve is installed as part of an assembly including the pump and the entire system must be grounded to prevent possible electrostatic discharge. Installation and adjustment guidelines are provided in this manual and are to be followed for the proper operation and performance of the valve.

Sound Levels:

These products are reactionary devices used in pumping systems. Sound levels are highly dependent upon the application, product being pumped, and installation. When operating in the system the valves should have a noise level no higher than 80 dBA.

Piping Forces and Moments:

Maximum Allowable Nozzle Forces and Moments

Note: Piping systems should be designed according to standard engineering practice and applicable national and local codes. NO piping induced forces or moments are recommended for Corken ZV200 bypass valves.

X—Horizontal (perpendicular to valve discharge port)

Y—Vertical

Z—Horizontal (parallel to valve discharge port)

$F_x = F_y = F_z = 42 \text{ lb (19 kg)}$

$M_x = M_y = M_z = 70 \text{ ft}\cdot\text{lb (10 kg}\cdot\text{m)}$

! Notice!

Corken bypass valves should only be installed in LPG & NH₃ systems that have been designed by qualified engineering personnel and operated and maintained by qualified technicians. The system must conform to all applicable local and national regulations and safety standards (specifically, LPG systems **must** conform to NFPA 58). This manual **must** be kept with the bypass valves and be reviewed **before** installing, operating or performing any maintenance work.

! Warning!

Do not attempt to open the pump or bypass valve until you have bled off the pressure. High pressure in the system can cause personal injury and/or property damage. Please note: if the system contains a meter, the differential valve will keep liquid under pressure in the pump, meter and piping even after the hose has been emptied.

Features of the ZV200 External Automatic Bypass Valve

The ZV200 is a low-pressure build-up external bypass valve designed to protect piping systems and sliding vane pumps from being over pressurized. It is suitable for flows up to 250 gpm (946 L/min). The continuous internal bleed assists with the operation of piping systems containing air or electric operated internal valves.

It is typically used for loading and unloading in both truck and stationary applications.

Installation of the ZV200 External Automatic Bypass Valve

An external bypass valve is an essential component of any pump application. It plays a key role in maximizing the performance and life of the pump by preventing excessive pressure resulting from accidental pump over-speed, a closed discharge line, or highly restrictive receiving systems.

Proper installation is critical to the performance of the bypass valve. Always install the bypass valve on the discharge side of the pump in either a vertical or horizontal position. The discharge line of the pump connects to the inlet of the bypass valve while the outlet of the valve runs back to the liquid or vapor section of the supply tank. **NOTE: Do not connect the outlet piping of the external bypass valve to the inlet piping of the pump.** To confirm the inlet and outlet of the bypass valve, a flow direction arrow can be found on the side.

The external bypass valve and piping system should be sized to accommodate the full flow of the pump at a normal operating speed with the discharge line closed. The piping sizes should match the sizes of the inlet and outlet of the bypass valve. **NOTE: If these guidelines are not followed, the actual operating pressures of the piping system can be higher than the bypass valve setting causing it to open prematurely and reduce the efficiency of the delivery.**

Operation of the ZV200 External Automatic Bypass Valve

The standard ZV200 external bypass valves are not preset at the factory. For optional spring ranges and settings, refer to the model identification table and part details in this manual.

Cold Temperature Operation: Impact strength is reduced at temperatures below -20°F (-28.9°C). Use extreme caution when working on the external bypass valve and prevent tools and other objects from impacting the pressurized components of the pumping system.

NOTE: After the external bypass valve has been installed in the piping system, the pressure setting must be verified.

Adjust the external bypass valve as follows:

The differential pressure setting of the ZV200 external bypass valve is adjustable; however, the range depends on the spring size supplied with the bypass valve. The tag attached to the cap of the bypass valve shows the spring range. The table below shows the part number for each spring size. **NOTE: All spring sizes are interchangeable.**

Flange Sizes	Spring Number	Differential Pressure (psig)
1-1/4", 1-1/2", 2", 2-1/2"	5513	41–70
	5515	71–90
	5511 (standard)	91–125
	5512	126–150

Truck Applications:

1. Install liquid-filled pressure gauges equipped with a needle valve or snubber in the following locations:
 - a. Pump discharge gauge port or inlet side of the bypass valve.
 - b. Supply tank and/or pump suction.
2. Connect the delivery hose to the receiving/storage tank or delivery tank port for recirculation.
3. All shut-off valves on the pump discharge line and bypass return line should be open.
4. Fully open the outlet valve of the supply tank and start pumping at a normal delivery rate. Make sure the direction of the rotating shaft follows the directional arrow located on the pump casing.
5. If the pump has an internal relief valve, check the pressure setting by slowly closing the shut-off valve on the bypass return line.
6. Slowly close the shut-off valve located on the pump's discharge line while observing the pressure gauge on the pump's discharge port. As the internal relief valve begins to open, the differential pressure typically drops. It is important to record the peak differential pressure (the difference between inlet and outlet pressure) before the internal relief valve opens. After circulation starts to flow through the internal relief valve, the pressure will drop significantly due to vaporization.

NOTE: The internal relief valve on the Z-Series truck pumps is pre-set at the factory and not adjustable in the field.

7. After the setting of the internal relief valve is confirmed, open the shut-off valves located on the pump discharge line and the bypass return line and resume normal operation of the pump.
8. To confirm the setting for the ZV200 external bypass valve, slowly close the shut-off valve in the pump's discharge line and record the pressure shown on the gauge. The difference between the pump's discharge pressure and the tank pressure (before pumping) is the setting of the external bypass valve.
8. If the pump is equipped with an internal relief valve, the ZV200 external bypass valve should be set 20–25 psi (1.38 to 1.72 bar) below the setting of the pump's internal relief valve. Following this guideline ensures the liquid does not recirculate through the internal relief valve and eliminates the possibility of erratic "hunting" between the two valves.
9. Reopen the shut-off valve in the pump's discharge line and resume normal operation of the pump. Record the pressure shown on the gauge. The difference between the pump's discharge pressure and the tank pressure (before pumping) is the normal operating pressure of the system.
10. If possible the setting of the ZV200 external bypass valve should be 15 psi (1.03 bar) higher than the normal operating pressure of the piping system. An operating pressure near the external bypass valve setting may cause the liquid to recirculate unnecessarily.
11. Adjust the pressure setting of the ZV200 external bypass valve if necessary. The external bypass valve can be adjusted by removing the valve cap and loosening the locknut.

WARNING: Use caution when removing the valve cap and follow the procedures below.

- a. To **increase** the pressure setting, loosen the locknut and turn the adjusting screw **clockwise**.
 - b. To **decrease** the pressure setting, loosen the locknut and turn the adjusting screw **counterclockwise**.
12. Once a satisfactory pressure adjustment has been achieved, attach the "tamper-proof" seal furnished with the external bypass valve to prevent unauthorized adjustments.

Notice!

1. If the external automatic bypass valve is sized and set correctly, a manual or hand operated bypass valve—if applicable—should remain in the closed position during normal operation. Keeping the manual or hand operated bypass valve closed ensures the external automatic bypass valve operates in a normal capacity.

2. Annual inspection and testing of the internal relief valve—if applicable—and the external automatic bypass valve are recommended. For testing procedures refer to the adjustment procedures listed in this manual.

Stationary applications equipped with an electric motor drive:

1. Install liquid-filled pressure gauges equipped with a needle valve or snubber in the following locations:
 - a. Pump discharge gauge port or inlet side of the bypass valve.
 - b. Supply tank and/or pump suction.
2. Attach an ammeter to a motor lead of the electric motor.
3. Remove the valve cap on the ZV200 external bypass valve and adjust to the lowest pressure setting by turning the adjusting screw **counterclockwise** until spring tension is no longer present. **Note: Do not remove the adjusting screw.**
4. Make sure the shut-off valves on the pump discharge line and bypass return line are in a fully open position.
5. Start the pump and circulate the liquid back to the supply tank using the discharge line.
6. Slowly close the shut-off valve located on pump discharge line so all of the liquid flows through the external bypass valve.
7. Slowly **increase** the setting of the ZV200 external bypass valve by turning the adjustment screw **clockwise** until the ammeter indicates the full-load current indicated on the motor nameplate or required differential pressure is reached. Record the pressure on the gauge mounted on the inlet side of the bypass valve.
9. If the pump has an internal relief valve, the ZV200 external bypass valve should be set at least 20–25 psi (1.38 to 1.72 bar) below the setting of the pump's built in relief valve. Following this guideline ensures the liquid does not recirculate through the internal relief valve and eliminates the possibility of erratic "hunting" between the two valves.
10. If possible the setting of the ZV200 external bypass valve should be 15 psi (1.03 bar) higher than the normal operating pressure of the piping system. An operating pressure near the external bypass valve setting may cause the liquid to recirculate unnecessarily.
11. Adjust the pressure setting of the ZV200 external bypass valve if necessary. The external bypass valve can be adjusted by turning the adjust screw **clockwise to increase** pressure and **counterclockwise to decrease** pressure.

12. Once a satisfactory pressure adjustment has been achieved, attach the “tamper-proof” seal furnished with the external bypass valve to prevent unauthorized adjustments.

13. Open the shut-off valve located on the pump discharge line downstream of the external bypass valve and continue pumping as needed.

WARNING: Do not adjust the external bypass valve beyond the range of the spring being used.

NOTE: On Anhydrous Ammonia and LP-Gas installations, follow the guidelines provided by Underwriter’s Laboratories, Inc. and NFPA Pamphlet # 58.

 **Notice!**

1. If the external automatic bypass valve is sized and set correctly, a manual or hand operated bypass valve—if applicable—should remain in the closed position during normal operation. Keeping the manual or hand operated bypass valve closed ensures the external automatic bypass valve operates in a normal capacity.
2. Annual inspection and testing of the internal relief valve—if applicable—and the external automatic bypass valve are recommended. For testing procedures refer to the adjustment procedures listed in this manual.

Appendix A—ZV200 Model Number and Identification Code

Base Model	ZV200
Inlet	2" NPT
Outlet	2" NPT
Maximum flow rate (gpm)	250
Ship weight lb (kg)	23 (10.4)

Model Number
Base X X X X

Springs	41–70 psig differential range	No charge option	A
	71–90 psig differential range	No charge option	C
	91–125 psig differential range	Standard	B
	126–150 psig differential range	No charge option	D

O-ring Material	Buna-N	Standard	A
	Neoprene ^{®1}	No charge option	B
	Viton ^{®1}	Charge option	D

Inlet Flanges	1.25" NPT	No charge option	A
	1.50" NPT	No charge option	C
	2.00" NPT	Standard	E
	2.50" NPT	No charge option	J
	1.25" Slip-on weld	Charge option	B
	1.50" Slip-on weld	Charge option	D
	2.00" Slip-on weld	Charge option	F
	2.50" Slip-on weld	Charge option	K

Outlet Flanges	1.25" NPT	No charge option	A
	1.50" NPT	No charge option	C
	2.00" NPT	Standard	E
	2.50" NPT	No charge option	J
	1.25" Slip-on weld	Charge option	B
	1.50" Slip-on weld	Charge option	D
	2.00" Slip-on weld	Charge option	F
	2.50" Slip-on weld	Charge option	K

¹Registered trademark of the DuPont company.

Appendix B—Specifications

Equipment Type

A low pressure build-up bypass valve.

Applications

Used with truck and stationary pumps for loading and unloading.

Features & Benefits

The continuous internal bleed will assist in the operation of systems with air or electric operated internal valves.

Operating Specifications

Maximum differential pressure	150 psid (10.34 bar)
Operating temperature range	Up to 225°F (107°C) ¹
Maximum working pressure	400 psi (27.6 bar)
Spring ranges	91–125 psi (6.3–8.6 bar) standard
	41–70 psi (2.8–4.8 bar) optional
	71–90 psi (4.9–6.2 bar) optional
	126–150 psi (9.0–10.3 bar) optional

Material Specifications

Part	Standard Material	Optional Material
Adjustment nut cap	ASTM A536 65-45-12	
Adjusting screw	Steel	
Valve body	Ductile iron: ASTM 536, 60-40-18	
Valve cap	Ductile iron: ASTM 536, 60-40-18	
Gasket	1010 hot rolled steel	
Flanges	Ductile iron: ASTM 536, 65-45-12 (NPT)	Plate steel: ASTM A516 (weld flange)
O-rings	Buna-N	Neoprene ^{®2} , Viton ^{®2}
Spring	Music wire/chrome silicon	
Spring guide	8620 A322 ASTM steel	
Relief valve	17-4 PH stainless steel	

¹Fitted with Buna-N O-rings.

²Registered trademark of the DuPont company.

Appendix C—Model ZV200 Performance

Differential Pressure psi (bar)	70 (4.82)	120 (8.27)
Maximum Rated Flow for Propane gpm (L/min)	180 (681)	250 (946)

Appendix D—Outline Dimensions for Model ZV200

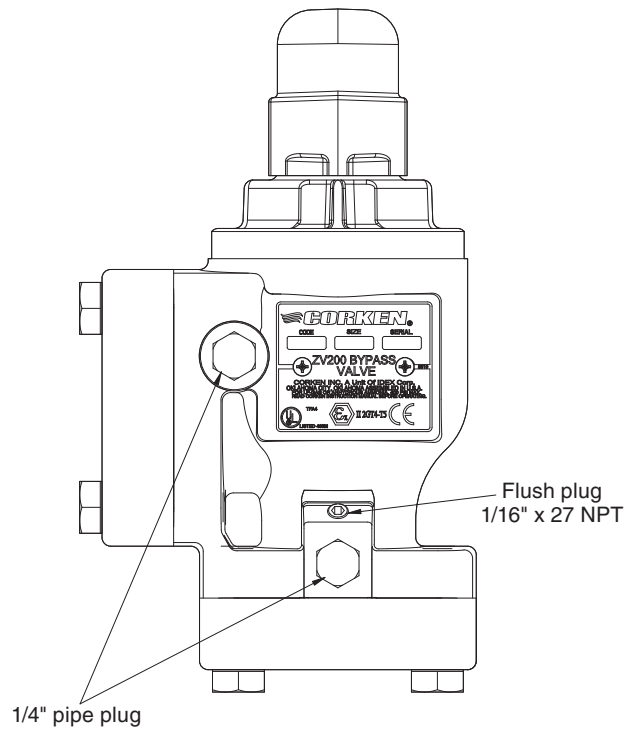
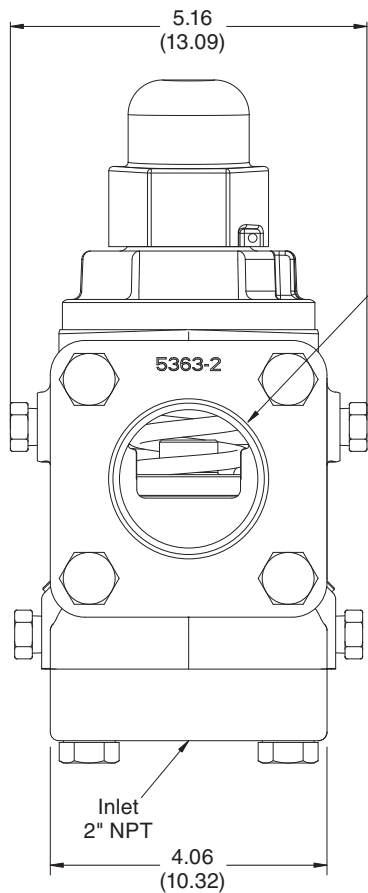
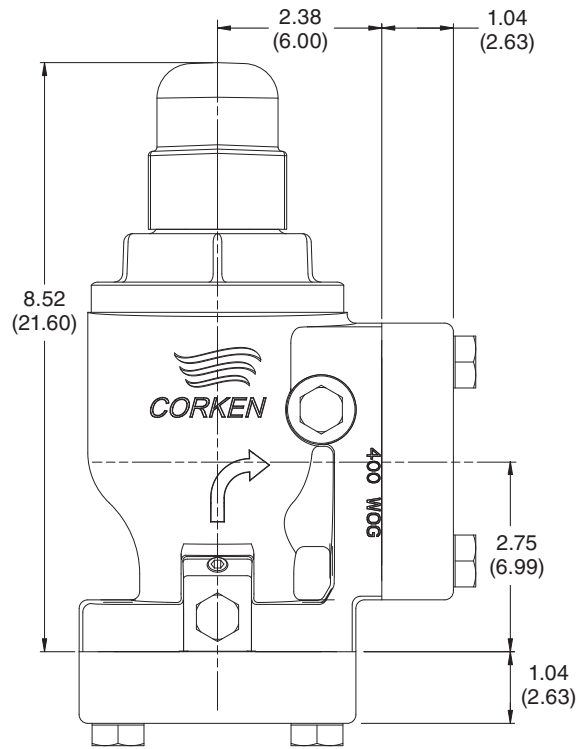

All dimensions are in inches (centimeters).

Appendix E—Parts Details for Model ZV200

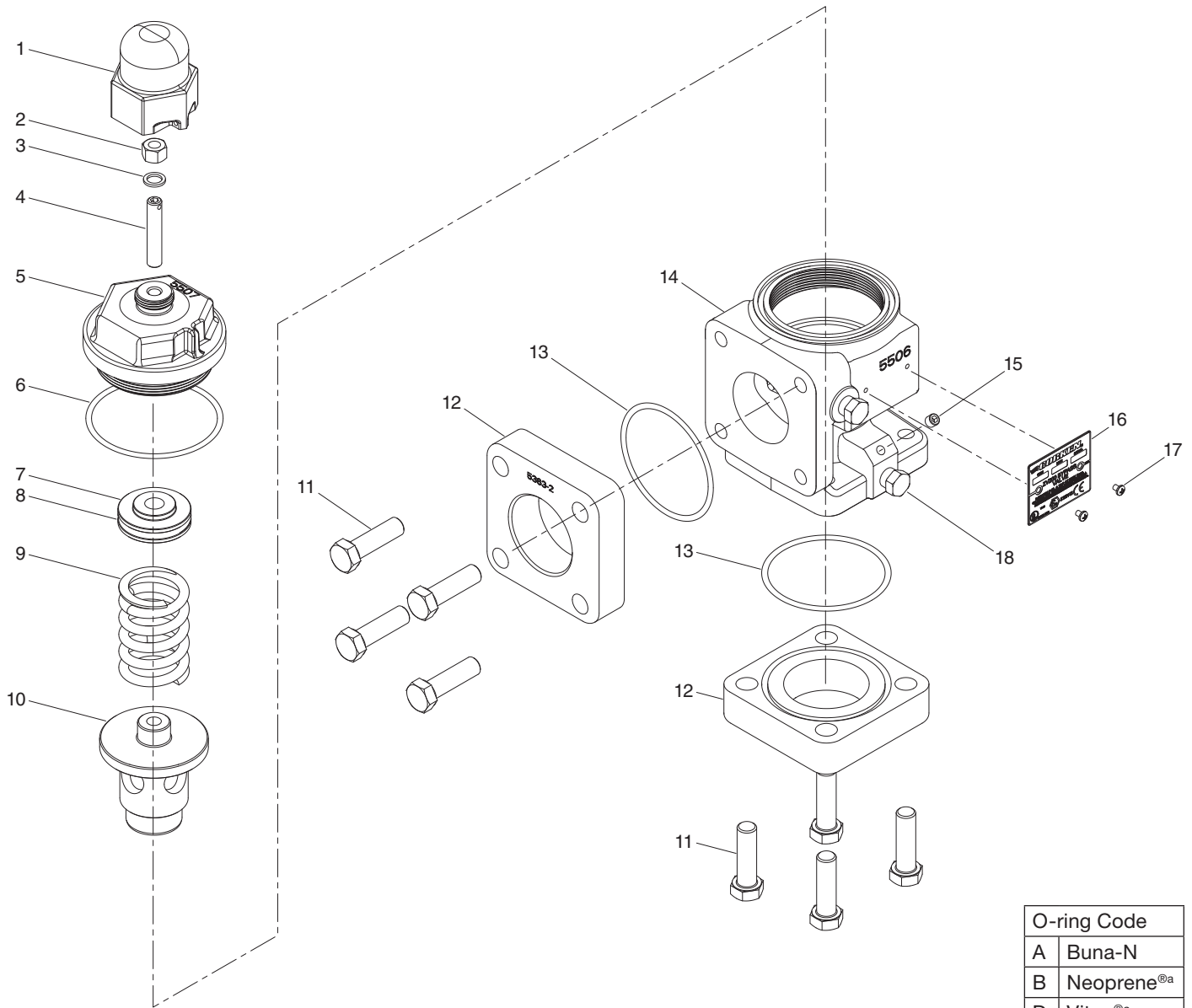

O-ring Code	
A	Buna-N
B	Neoprene ^{®a}
D	Viton ^{®a}

Ref. No.	Part No.	Description	Qty
1.	5457	Adjustment nut cap	1
2.	7101-037NC01A	Hex nut	1
3.	2732	Gasket	1
4.	2911	Adjusting screw	1
5.	5507	Bypass valve cap (2")	1
6.	2-235 _b	O-ring	1
7.	2-223 _b	O-ring	1
8.	5516	Spring guide (2")	1
	5512	Valve spring (126–150 psi)	1
9.	5513	Valve spring (41–70 psi)	1
	5515	Valve spring (71–90 psi)	1
10.	5509	Relief valve (2")	1
	5511	Valve spring (91–125 psi)	1

^aRegistered trademark of the DuPont company.
^b_b denotes O-ring code. See chart above.

Ref. No.	Part No.	Description	Qty
11.	7001-050NC175A	Hex head bolt	8
12.	5363-1.25	Flange (1.25" NPT)	2
	5363-1.5	Flange (1.5" NPT)	2
	5363-2	Flange (2" NPT)	2
	5363-2.5	Flange (2.5" NPT)	2
	5363-1.25S	Flange (1.25" slip weld)	1
	5363-1.5S	Flange (1.5" slip weld)	1
13.	5363-2S	Flange (2" slip weld)	2
	5363-2.5S	Flange (2.5" slip weld)	2
13.	2-234 _b	O-ring	2
14.	5506	Bypass valve body	1
15.	1629	Flush plug 1/16" x 27 NPT	2
16.	5510	Nameplate	1
17.	7012-006SF019E	Pan hd. Phillip 6-32 x 3/16"	2
18.	3442	Pipe plug 1/4" NPT	4

Appendix F—Troubleshooting Guide for the ZV200 Bypass Valve

Problem	Cause	Solution
Low capacity	Valve set too low. Note: After all potential causes from the pump and system have been investigated	Adjust valve as demonstrated in this IOM manual on pages 5–7.
Adjusting screw will not turn	Screw adjusted full in	Adjustment too high—back out adjustment and adjust valve per instructions in this IOM manual on pages 5–7.
Noise from valve during system operation	Spring broken	Depressurize system. Open valve and inspect. Replace spring if necessary.
	Adjustment screw set too far out	Adjust valve per instructions in this IOM manual on pages 5–7.
	Excessive restriction in return line	Remove restrictions.
Valve leaking product	O-ring failure	Depressurize system. Open valve and inspect. Replace O-ring.
	Fitting loose	Identify and tighten fitting.
Valve will not adjust to desired pressure	Spring guide or O-ring failure	Depressurize system. Open valve and inspect O-ring and spring guide.

Appendix G—Extended Storage of the ZV200 Bypass Valve

If your bypass valve is to be removed from service for some time, it must be protected as propane, butane and anhydrous ammonia all leave the metal “bare” and open to corrosion. Piping and tanks not in service should also be protected as the rust particles can destroy the pump’s seals almost immediately after startup.

1. Fill or thoroughly flush the bypass valve with a light rust inhibiting oil. (If the bypass valve is flushed with oil, placing some desiccant packets inside the bypass valve will provide added protection.)
2. Plug all bypass valve openings.
3. Store in a dry location.
4. Before placing the bypass valve back into service, drain the oil and remove any desiccant packets.
5. Refer to pages 5–7.

Solutions beyond products...

CORKEN®

CORKEN, INC. • A Unit of IDEX Corporation

9201 North I-35 Service Road, Oklahoma City, OK. 73131

Phone (405) 946-5576 • Fax (405) 948-7343

Visit our website at <http://www.corken.com>

or e-mail us at cocsalesdept@idexcorp.com

