

Appendix E—Parts Details for Seal Assembly (2296 Series)

Models D51 and F51

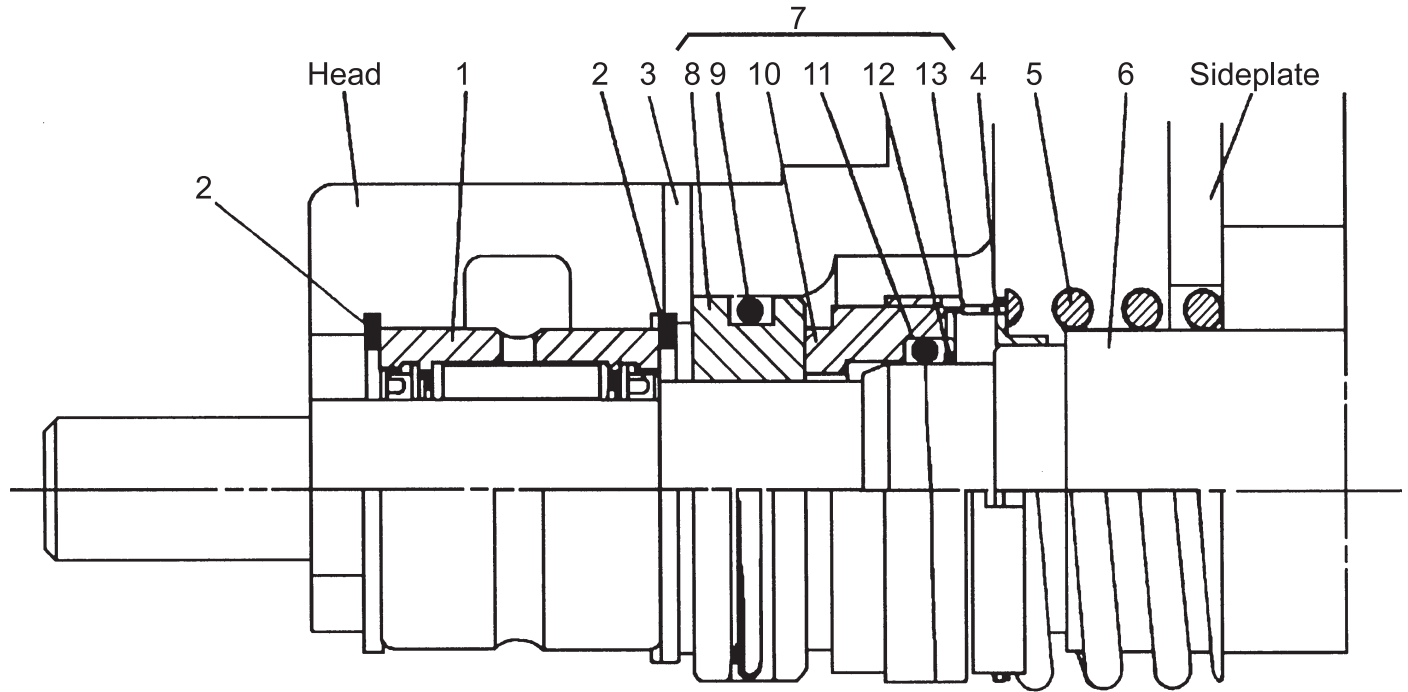

Ref No.	Part No.	Description	Qty.
1.	2471	Roller bearing	1
2.	5000-112	Retainer ring	1
3.	2595	Seat location pin	1
4.	2735	Drive band (with 2492-X)	1
5.	3471	Spring (with 2492-X)	1
6.	2492-X	Rotor and shaft assembly	1
7.	2296-X_6 ^{a, b}	Seal	1
	2296-1X_6 ^{a, b}	Seal Assembly	1
8.	Not sold separately ^c	Silicon carbide seal seat	1
9.	Not sold separately ^c	Seat O-ring	1
10.	Not sold separately ^c	Rotor	1
11.	Not sold separately ^c	O-ring	1
12.	Not sold separately ^c	Disc	1
13.	Not sold separately ^c	Retainer	1

Material Code	
A	Buna-N
B	Neoprene ^{®d}



CAUTION: Always relieve pressure in the unit before attempting any repairs.

^a _ denotes material code. See material code chart for details.

^b Seal assembly includes the seal and a 2-154_^a case O-ring.

^c Not sold separately. These items are included in both the seal and the seal assembly.

^d Registered trademark of the DuPont company.

Appendix E—Parts Details for Model D51 (Direct Mount)



CAUTION: Always relieve pressure in the unit before attempting any repairs.

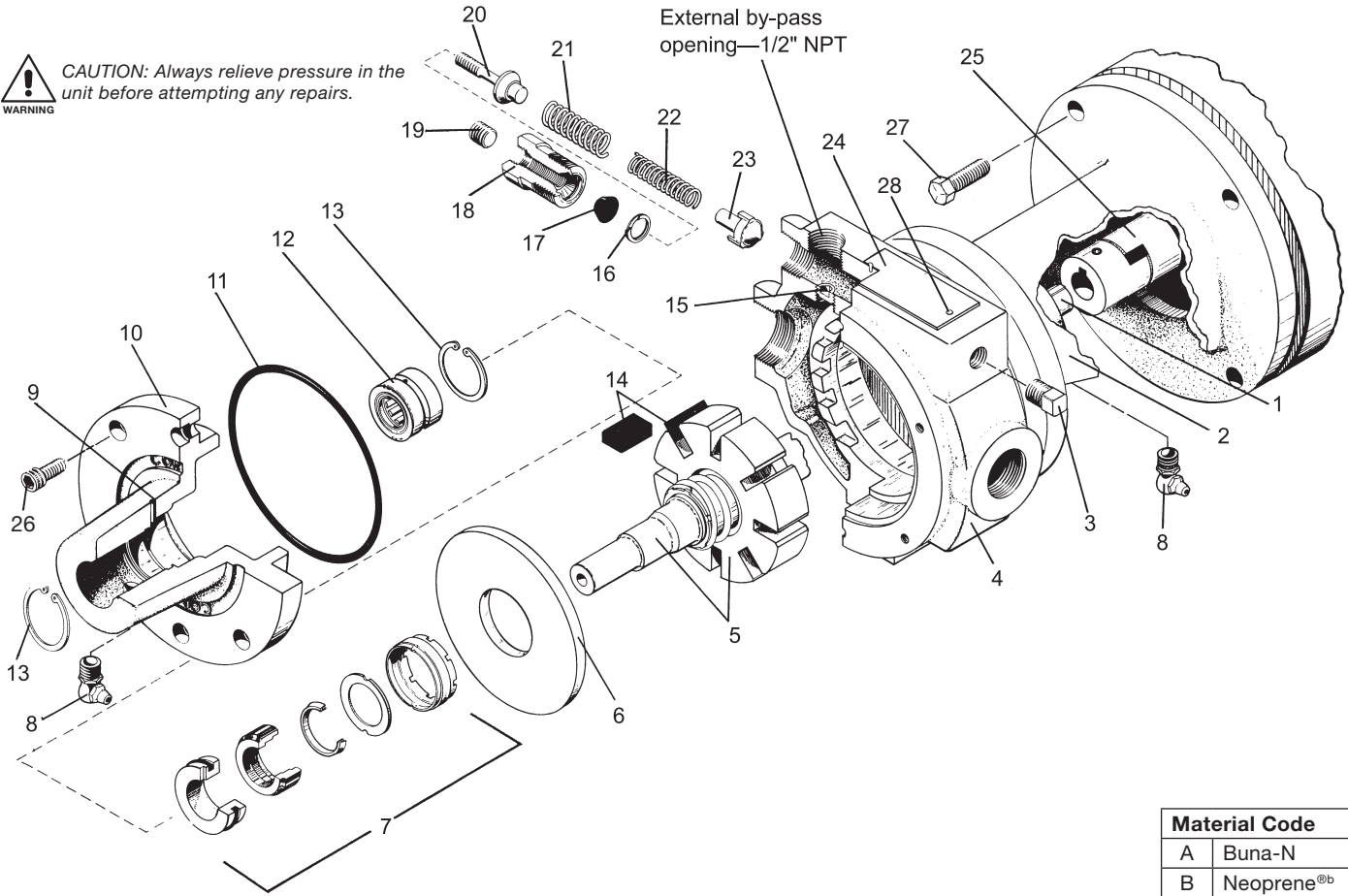

Material Code	
A	Buna-N
B	Neoprene ^{®b}

Ref No.	Part No.	Description	Qty.
1.	2592	Key—1/8" sq. x 9/16"	1
2.	2510	Mounting bracket	1
3.	3442	Pipe plug—1/4" NPT	1
4.	2468	Case	1
5.	2492-X	Rotor and shaft assembly	1
6.	2491	Sideplate	2
7.	2296-1X_6 ^a	Seal assembly	2
8.	2604	Elbow grease zerk—1/8" NPT	2
	2159	Lubricap #2 (not shown)	2
9.	2595	Seat location pin	2
10.	2472	Head	2
11.	2-154 ^a	Case O-ring	2
12.	2471 ^d	Roller bearing	2
13.	5000-112	Retainer ring	4
14.	2451-2	Carbon vane	8
15.	2590 ^c	Flush plug—1/8" NPT	1
16.	2760-53	Retainer ring	1
17.	2589	Stem seal	1
18.	2585	Relief valve plug	1
19.	2590	Flush plug—1/8" NPT	1
20.	2584-X	Adjusting stem assembly	1
21.	2587 ^c	Outer relief valve spring	1
22.	2586 ^c	Inner relief valve spring	1
23.	2588	Relief valve	1
24.	2591	Nameplate	1
25.	2593-1	Coupling with spider	1
	2774	Coupling spider only	1

Ref No.	Part No.	Description	Qty.
26.	7002-025NC062A	Bolt socket head	9
27.	7001-037NC100A	Bolt hex head	4
28.	7012-006SF019E	Nameplate screw	2

^a _ denotes material code. See material chart for details.

^b Registered trademark of the DuPont company.

^c The pump relief valve is installed at the factory to operate as an external bypass through the 1/2" NPT hole back to the storage tank. To change from this external configuration to an internal relief valve, remove relief valve plug 2585 and relief valve springs 2586 and 2587. Then remove flush seal plug 2590 and plug the 1/2" NPT opening. Replace the relief valve plug and springs. In this case a separate external bypass valve must be used in the piping between the pump discharge and the storage tank. Set the internal valve at a pressure slightly above the setting on the external valve. Use only the outer relief valve spring 2587 for units with 1/3 hp motors. Use both springs for 1/2 hp motors and larger. Always replace the flush seal plug 2590 that screws into the relief valve plug 2585 after any relief valve adjustment.

^d Bearing replacement: Install roller bearing 2471 with open side of grease seals toward outside of pump as shown below.

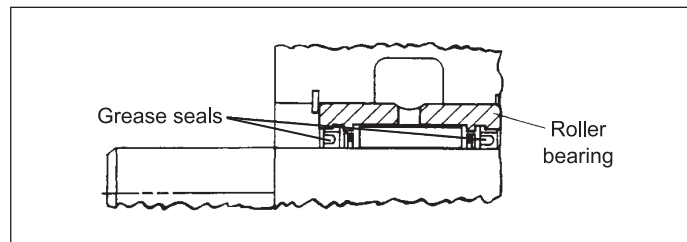

Appendix E—Parts Details for Model F51 (Frame Mount)



CAUTION: Always relieve pressure in the unit before attempting any repairs.

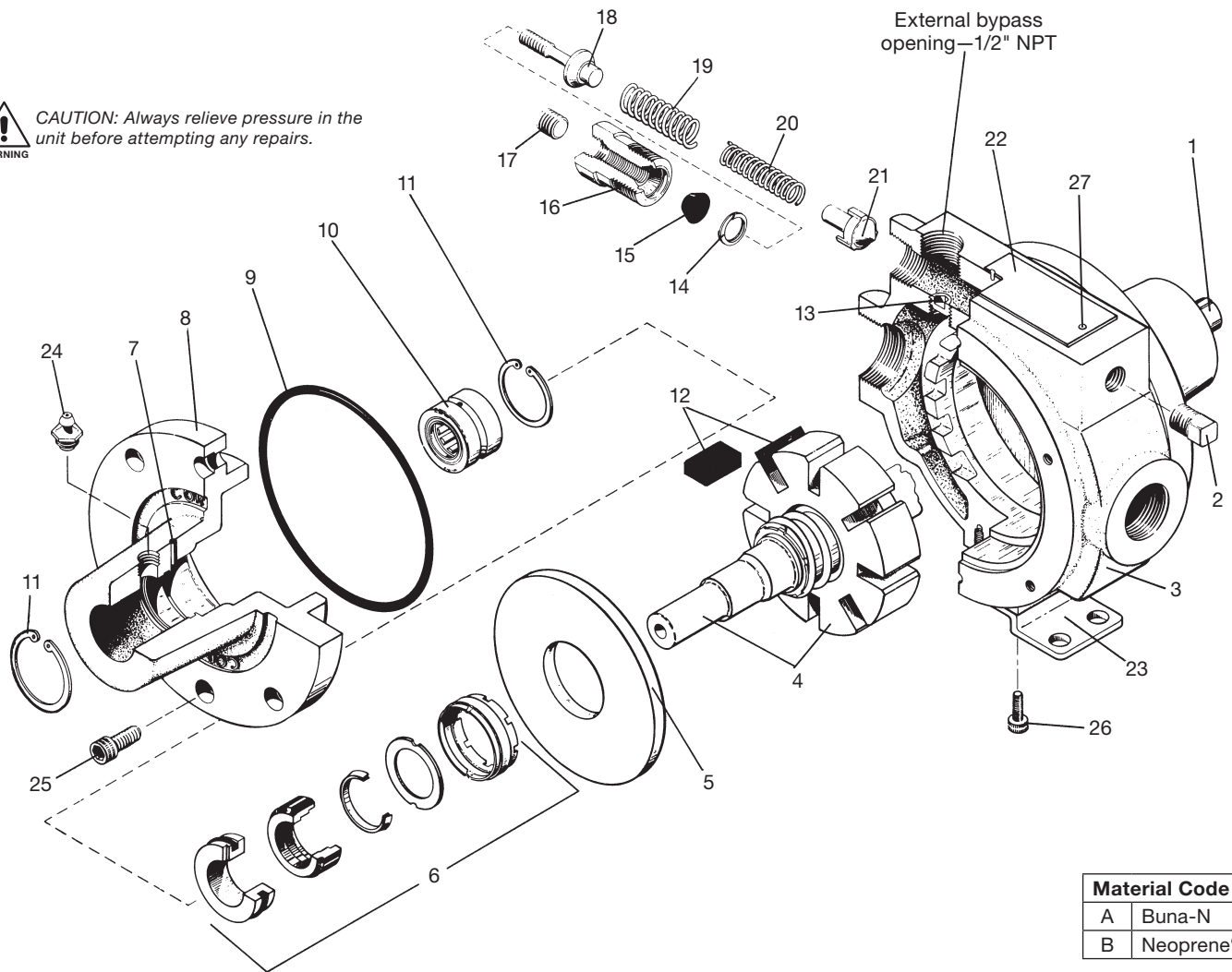

Material Code	
A	Buna-N
B	Neoprene ^{®b}

Ref No.	Part No.	Description	Qty.
1.	2592	Key—1/8" sq. x 9/16"	1
2.	3442	Pipe plug—1/4" NPT	1
3.	2468-1	Case	1
4.	2492-X	Rotor and shaft assembly	1
5.	2491	Sideplate	2
6.	2296-1X_6 ^a	Seal assembly	2
7.	2595	Seat location pin	2
8.	2472	Head	2
9.	2-154_ ^a	Case O-ring	2
10.	2471 ^d	Roller bearing	2
11.	5000-112	Retainer ring	4
12.	2451-2	Carbon vane	8
13.	2590 ^c	Flush plug—1/8" NPT	1
14.	2760-53	Retainer ring	1
15.	2589	Stem seal	1
16.	2585	Relief valve plug	1
17.	2590	Flush plug—1/8" NPT	1
18.	2584-X	Adjusting stem assembly	1
19.	2587 ^c	Outer relief valve spring	1
20.	2586 ^c	Inner relief valve spring	1
21.	2588	Relief valve	1
22.	2591	Nameplate	1
23.	2594	Base	1
24.	2158	Grease zerk—1/8" NPT	2
	2159	Lubricap #2 (not shown)	2

Ref No.	Part No.	Description	Qty.
25.	7002-025NC062A	Bolt socket head	12
26.	7002-010NC050A	Bolt socket head	3
27.	7012-006SF019E	Nameplate screw	2

^a _ denotes material code. See material chart for details.

^b Registered trademark of the DuPont company.

^c The pump relief valve is installed at the factory to operate as an external bypass through the 1/2" NPT hole back to the storage tank. To change from this external configuration to an internal relief valve, remove relief valve plug 2585 and relief valve springs 2586 and 2587. Then remove flush seal plug 2590 and plug the 1/2" NPT opening. Replace the relief valve plug and springs. In this case a separate external bypass valve must be used in the piping between the pump discharge and the storage tank. Set the internal valve at a pressure slightly above the setting on the external valve. Use only the outer relief valve spring 2587 for units with 1/3 hp motors. Use both springs for 1/2 hp motors and larger. Always replace the flush seal plug 2590 that screws into the relief valve plug 2585 after any relief valve adjustment.

^d Bearing replacement: Install roller bearing 2471 with open side of grease seals toward outside of pump as shown below.

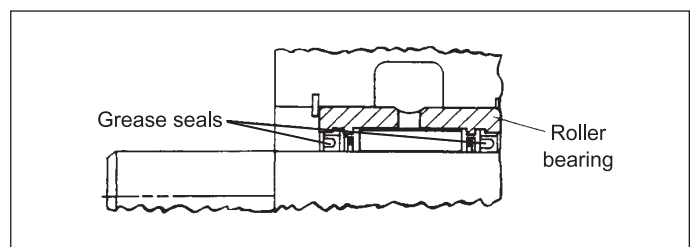

Appendix E—Parts Details for Seal Assembly (1769 Series)

All Models 521 and 1021



CAUTION: Always relieve pressure in the unit before attempting any repairs.

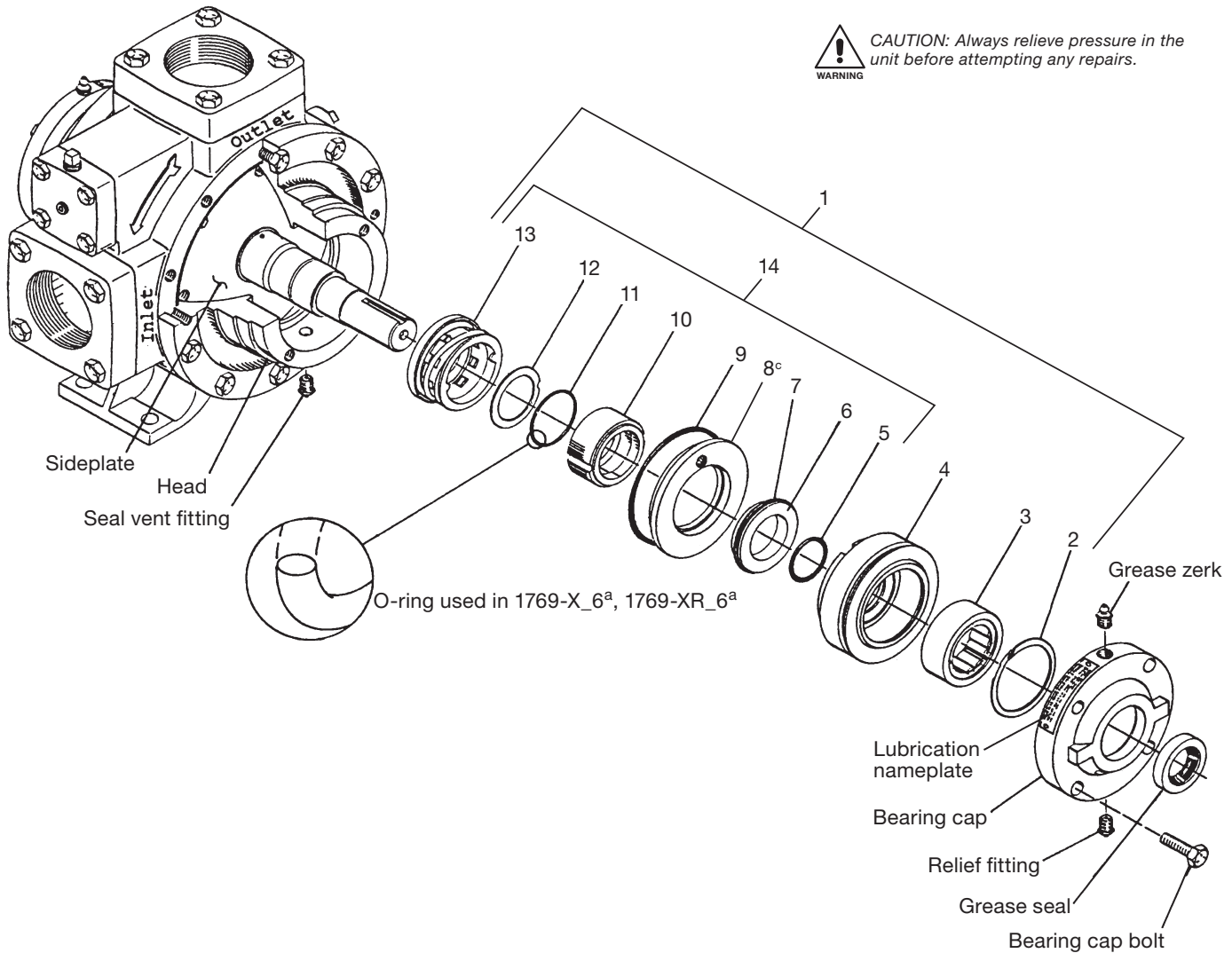

Ref No.	Part No.	Description	Qty.
1.	1769-X_6 ^a	Complete seal assembly	1
2.	2760-244	Retainer ring	1
3.	2754-X	Roller bearing, complete	1
	2754	Bearing outer race	1
	2755	Bearing inner race	1
4.	1769	Bearing housing	1
5.	2-128_ ^a	Shaft O-ring	1
6.	Not sold separately ^d	Seal seat	1
7.	2-227_ ^a	Seat O-ring	1
8.	1822 ^c	Seat adapter plate	1
9.	2-240_ ^a	Adapter plate O-ring	1
10.	Not sold separately ^d	Carbon seal	1
11.	2-223_ ^a	Rotor O-ring	1
12.	Not sold separately ^d	Disc	1
13.	Not sold separately ^d	Retainer assembly	1
14.	1769-XR_6 ^a	Field replacement seal assembly	1

Material Code	
A	Buna-N
B	Neoprene ^{®b}

^a _ denotes material code. See material code chart for details.

^b Registered trademark of the DuPont company.

^c Not included in field replacement seal assembly.

^d Not sold separately. Available with 1769-X_6^a and 1769-XR_6^a only.

Appendix E—Parts Details for Models 521 and 1021

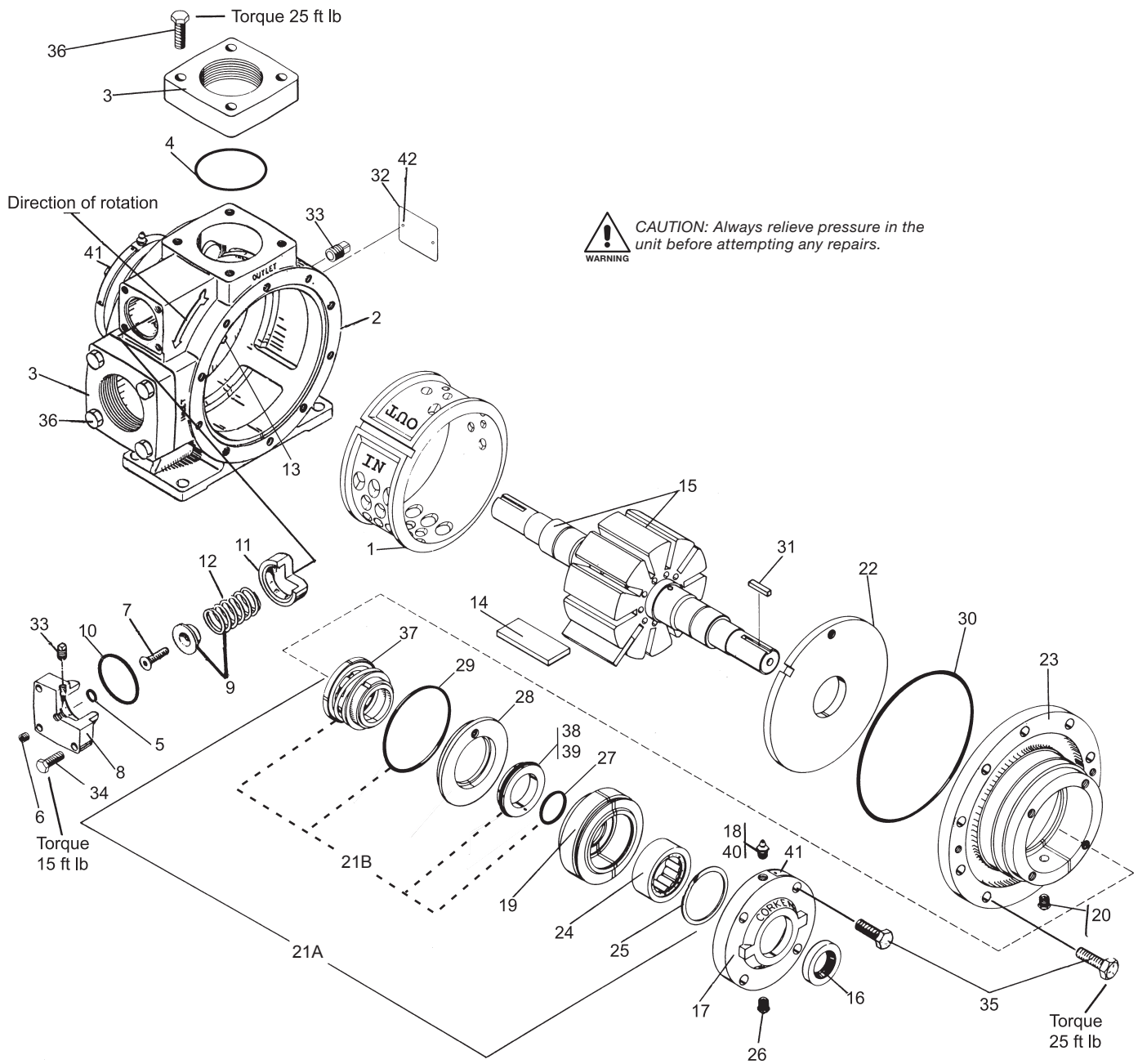

Sideplate Replacement Instructions

Model 521

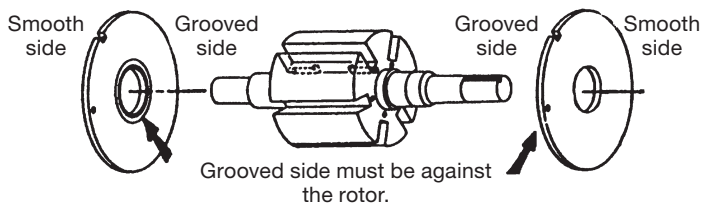

Model 1021

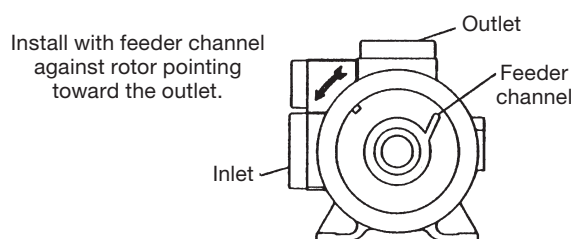

Appendix E—Parts Details for Models 521 and 1021

Ref No.	Part No.	Description	Qty.
1.	1162-2	Cam (521)	1
	1201-2	Cam (1021)	1
2.	2832	Case (521)	1
	2841	Case (1021)	1
3.	1172-2.5	Flange—2-1/2" standard (521)	1
	1172-2	Flange—2" standard (521)	1
	1172-1.5	Flange—1/2" NPT, optional (521)	1
	1172-15S	Flange—1/2" Weld, optional (521)	1
	1172-2	Flange—2" NPT, optional (521)	1
	1172-2S	Flange—2" Weld, optional (521)	1
	1172-2.5	Flange—2-1/2" NPT, optional (521)	1
	1172-2.5S	Flange—2-1/2" Weld, optional (521)	1
	1206-34	Flange—3" standard (1021)	2
	1206-3S	Flange—3" Weld, optional (1021)	2
	1206-4	Flange—4" NPT, optional (1021)	2
	1206-4S	Flange—4" Weld, optional (1021)	2
	4.	2-234 _a	Flange O-ring (521)
2-245 _a		Flange O-ring-3" (1021)	2
2-249 _a		Flange O-ring-4" (1021)	2
5.	2-112 _a	Adjusting screw O-ring	1
6.	2590	Flush plug—1/8" NPT	1
7.	2252	Relief valve adjusting screw	1
8.	1174	Valve cap (521)	1
	1207	Valve cap (1021)	1
9.	1242-X	Relief valve spring and guide (521)	1
	1227	Relief valve spring guide (1021)	1
10.	2-224 _a	Relief valve cap O-ring (521)	1
	2-228 _a	Relief valve cap O-ring (1021)	1
11.	1241	Relief valve (521)	1
	1224	Relief valve (1021)	1
12.	1242	Relief valve spring (521)	1
	1226	Relief valve spring (1021)	1
13.	1170	Cam key (521)	1
	1309	Cam key (1021)	1
14.	1168-7	Blade (521)	10
	1308-9	Blade (1021)	10
15.	1166-1X1R	Rotor and shaft assembly (521)	1
	1208-1X1R	Rotor and shaft assembly (1021)	1
16.	1358	Grease seal	2
17.	1164-1	Bearing cap	2
18.	2158	Grease zerk—1/8" NPT	2
19.	1769	Bearing housing	2
20.	1343	Seal vent relief fitting—1/8" NPT	2

Ref No.	Part No.	Description	Qty.
21A.	1769-X ₆ ^a	Complete seal assembly kit. Includes bearing housing, seat adapter plate, bearings, retainer rings, seal, and O-rings.	2
21B.	1769-XR ₆ ^a	Seal assembly field replacement kit. Includes only the seal and O-rings.	2
22.	1163-2 ^d	Sideplate (521)	2
	1209-1 ^d	Sideplate (1021)	2
23.	1161-4	Head (521)	2
	1205-4	Head (1021)	2
24.	2754-X	Roller bearing—complete	2
	2755	Bearing inner race	2
	2754	Bearing outer race	2
25.	2760-244	Retainer ring	2
26.	1343	Grease relief fitting—1/8" NPT	2
27.	2-128A	Shaft O-ring (Buna-N only)	2
28.	1882	Seat adapter plate	2
29.	2-240 _a	Adapter plate O-ring	2
30.	2-261 _a	Case O-ring (521)	2
	2-268 _a	Case O-ring (1021)	2
31.	2270	Key—1/4"	2
32.	2949	Nameplate	1
33.	3442	Plug—1/4" NPT	1
34.	7001-031NC125A	Hex head bolt—5/16-18x1-1/4 (521)	4
	7001-037NC125A	Hex head bolt—3/8-16x1-1/4 (1021)	4
35.	7001-037NC125A	Hex head bolt—3/8-16x1-1/4 (521)	28
	7001-037NC125A	Hex head bolt—3/8-16x1-1/4 (1021)	32
36.	7001-037NC150A	Hex head bolt—3/8-16x1-1/2	8
37.	Not sold separately ^b	Retainer	2
38.	Not sold separately ^b	Seal seat	2
39.	2-227 _a	Seal seat O-ring	2
40.	2159	Lubricap #2	2
41.	1359	Lubrication instruction tag	2
42.	7003-004DR0198	Round head plated drive screw—4 x 3/16	2

Material Code	
A	Buna-N
B	Neoprene ^{®c}
D	Viton ^{®c}
E	PTFE

^a _ denotes material code. See material code chart for details.

^b Not sold separately. Available with 1769-X₆^a, and 1769-XR₆^a only.

^c Registered trademark of the DuPont company.

^d See sideplate replacement instructions.

Appendix E—Parts Details for Model F1021

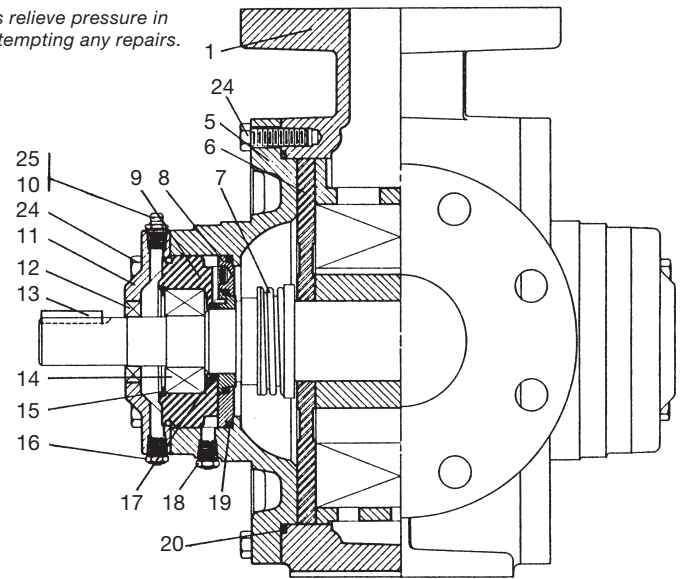
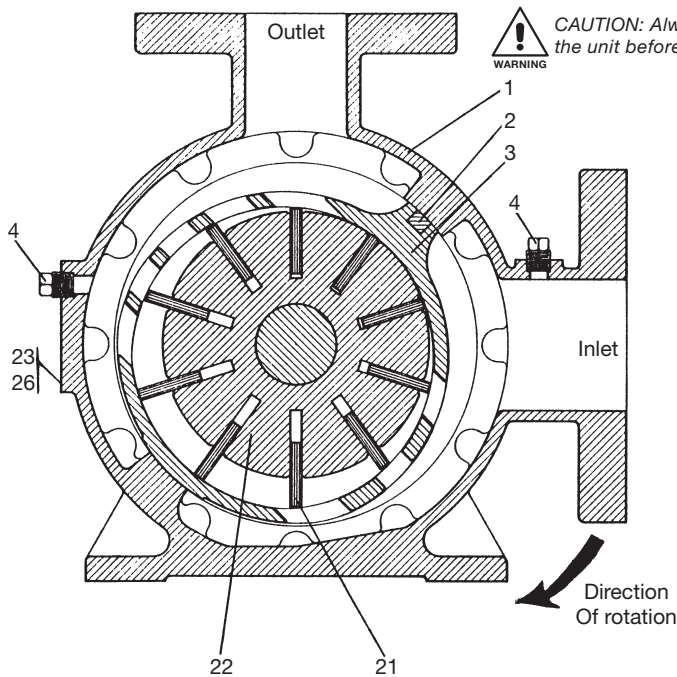

Ref No.	Part No.	Description	Qty.
1.	2433	Case	1
2.	1309	Cam key	1
3.	1201-2	Cam	1
4.	3442	Plug—1/8" NPT	2
5.	1205-4	Head	2
6.	1209-1 ^d	Sideplate	2
7.	1769-X ₆ ^a	Complete seal assembly kit. Includes bearing housing, seat adapter plate, bearings, retainer rings, seal, and O-rings.	2
	1769-XR ₆ ^a	Seal assembly field replacement kit. Includes only the seal and O-rings.	2
8.	1822	Seat adapter plate	2
9.	1769	Bearing house	1
10.	2158	Grease zerk—1/8" NPT	1
11.	1164-1	Bearing cap	2
12.	1358	Grease seal	1
13.	2270	Key—1/4"	1
14.	2754-X	Roller bearing—complete	2
	2755	Bearing inner race	2
	2754	Bearing outer race	2
15.	2760-244	Retainer ring	1
16.	1343	Grease relief fitting—1/8" NPT	2
17.	2-128A	Shaft O-ring (Buna-N only)	1
18.	1343	Seal vent relief fitting—1/8" NPT	1
19.	2-240 ^a	Adapter plate O-ring	1
20.	2-268 ^a	Case O-ring	2

Ref No.	Part No.	Description	Qty.
21.	1308-9	Vane	10
22.	1208-1X1R	Rotor and shaft assembly with 2755	1
23.	2649	Nameplate	1
24.	7001-037NC125A	Hex head bolt—3/8-16x1-1/4"	32
25.	2159	Lubricap #2	2
26.	7012-006SF019E	Round head drive screw—6-32x3/16	6

Material Code	
A	Buna-N
B	Neoprene ^{®b}

^a _ denotes material code. See material code chart for details.

^b Registered trademark of the DuPont company.

^c See sideplate replacement instructions.

Sideplate Replacement Instructions

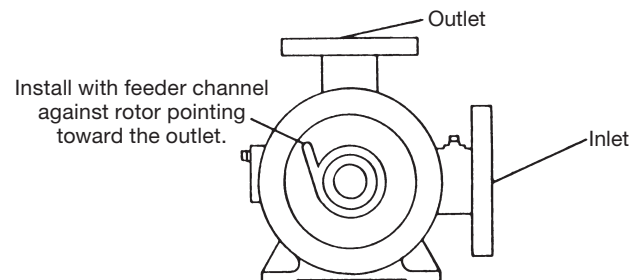

Appendix E—Parts Details for Rotor, Blade, Sideplate, and Cam

New Part Interface Dimensions

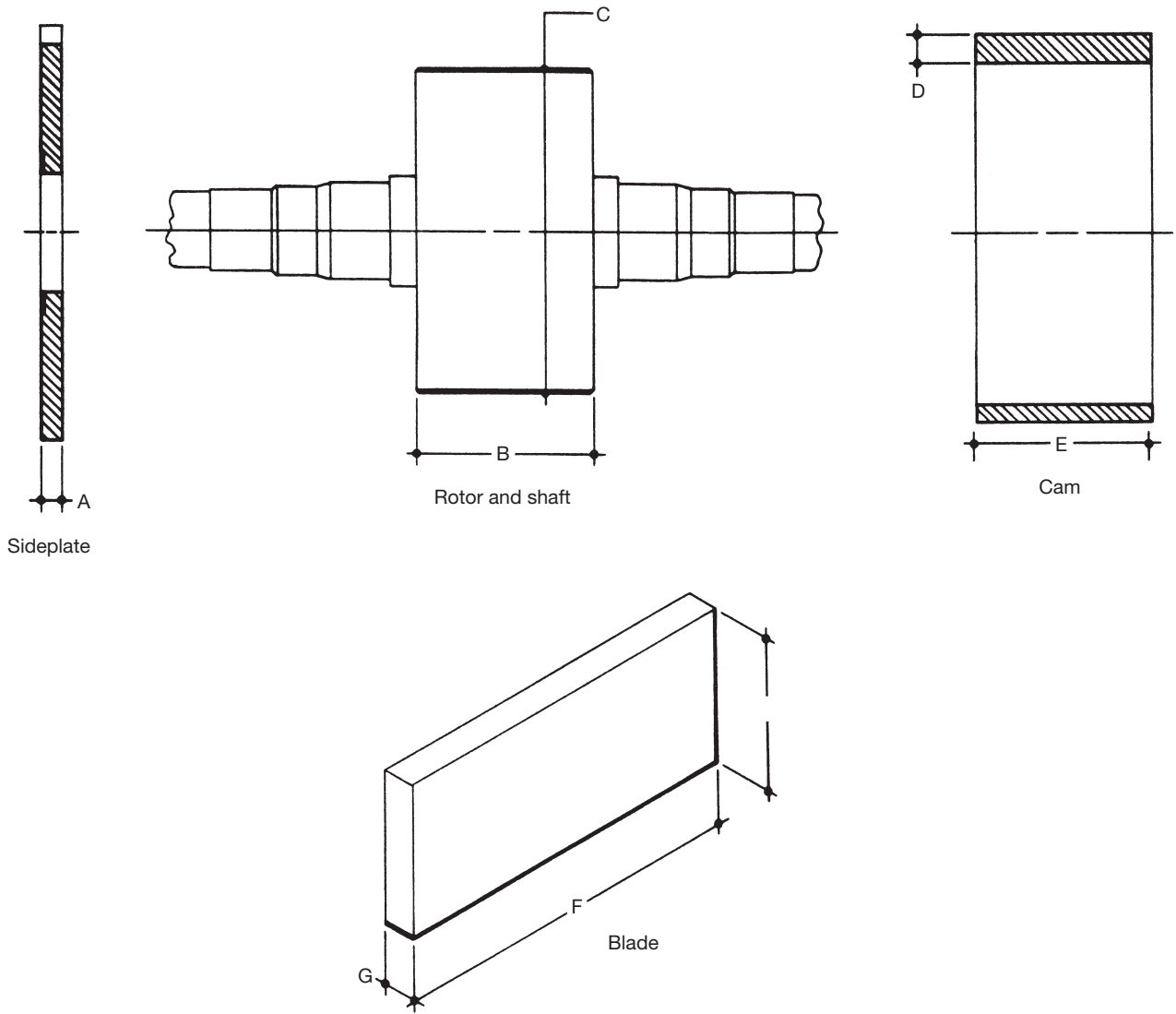

Model	A (min)	B (max)	C (max)	D (max)	E (min)	F (max)	G (max)	H (nominal)
500	0.373	2.992	5.449	0.750	3.000	2.994	0.230	1.323
1000	0.435	3.993	6.249	1.123	4.002	3.997	0.230	1.500
1500	0.435	6.243	6.125	1.184	6.253	6.229	0.549	1.635