

New Enhancements on the Z3200 Truck Pump

CORKEN has enhanced the performance and packaging of the Z3200 truck pump. These industry leading enhancements improve the reliability and performance of the seal assembly, longevity of the vanes and vane drivers, and durability of the product packaging.

Improved vane design: 100% increase in leading edge surface area providing exceptional durability and longevity.

60% stronger vane driver material: New material resists wear and improves high RPM durability.

Extended life seal seat material: Provides maximum sealing performance and reduces maintenance.

Individually packaged: Each pump is palletized and boxed individually for easier handling and greater protection during transit.

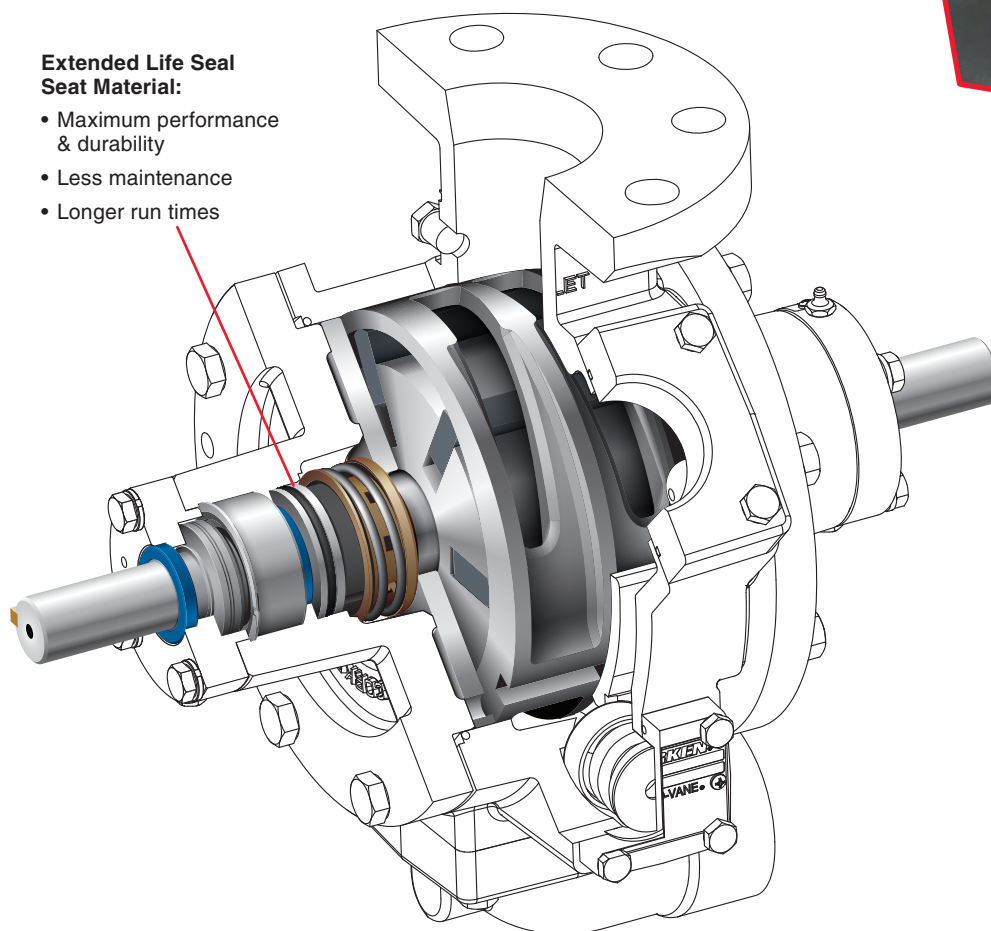

Extended Life Seal Seat Material:

- Maximum performance & durability
- Less maintenance
- Longer run times

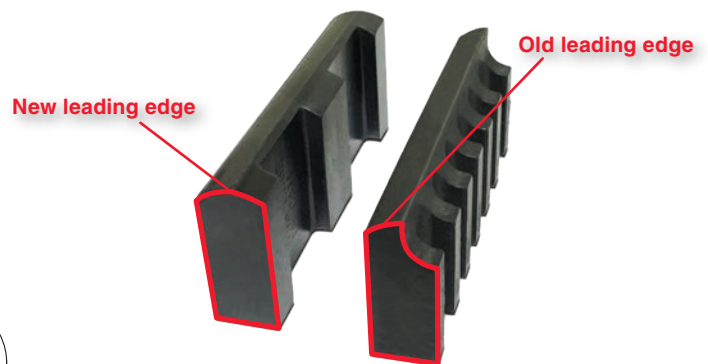

Leading edge of vane has 2X the thickness:

- Extends vane life
- Improves durability

60% stronger vane driver material:

- Increased wear resistance and durability.

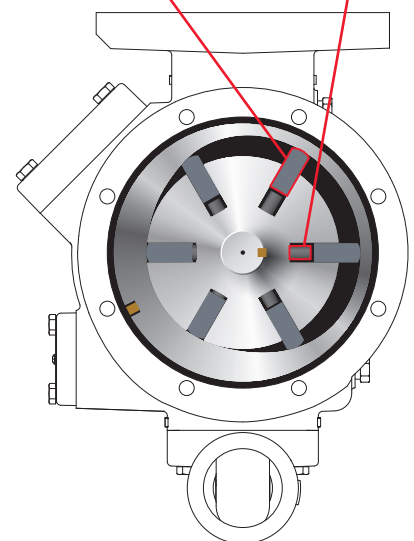

Since the outward appearance of the enhanced Z3200 is the same as the previous design, the enhanced model has a couple of distinguishing marks. The first distinction is the model number. All enhanced versions of the Z3200 have a seven digit specification field following the model number. For example a Z3200HGA6PGE is the new configuration for standard flanges. There will always be a “6” in the fourth position from the model number indicating the new seal seat material, silicon carbide. Pictured to the right is an example of the new model number shown on a CORKEN nameplate.



Example of the new model number shown on a CORKEN nameplate.

The second distinction is the ½” drilled countersink within the pump head on the same circumference as the eight head bolts. If the pump is mounted to the bottom of a truck tank, it is located opposite the suction flange in the 6 o’clock position. If it’s still on the original shipping pallet it will be in the 12 o’clock position. For details on the countersink see photos below.

NOTE: To take advantage of these new enhancements, please use the new model number on your next purchase order.



½” drilled countersink on a new pump’s head.



Old pump without the drilled countersink.

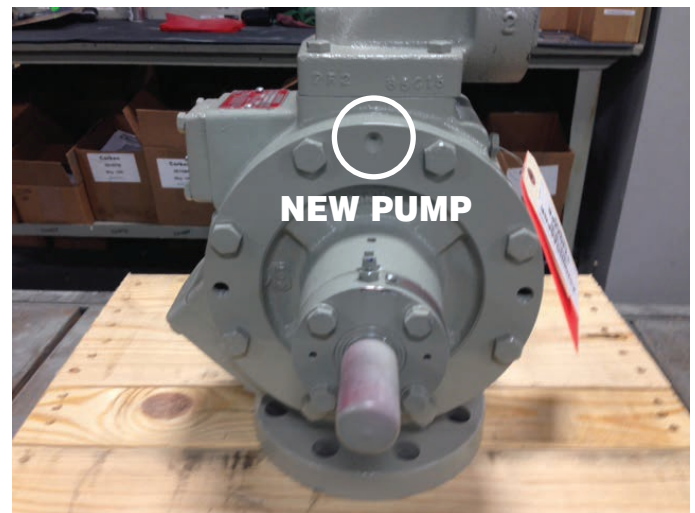

New pump with the drilled countersink at the 12 o'clock position.

Solutions beyond products...



CORKEN, INC. • A Unit of IDEX Corporation
 9201 North I-35 Service Road, Oklahoma City, OK. 73131 U.S.A.
 Phone (405) 946-5576 • FAX (405) 948-7343
 Visit our website at www.corken.com
 E-mail us at cocsalesdept@idexcorp.com

