

## Performance Enhancements for the Z4200 Truck Pump

CORKEN has enhanced the performance of the Z4200 truck pump. The industry leading enhancements improve the reliability and performance of the seal assembly, vanes, and vane drivers.

- Improved Vane Design:**  
 A 100% increase in the surface area of the leading edge improves durability.
- New Material for Vane Drivers:**  
 The new material is 60% stronger and lasts longer in high RPM applications.
- Silicon Carbide Seal Seat:**  
 Offers unmatched sealing performance and a longer service life.

### Flow Rate Comparison\*

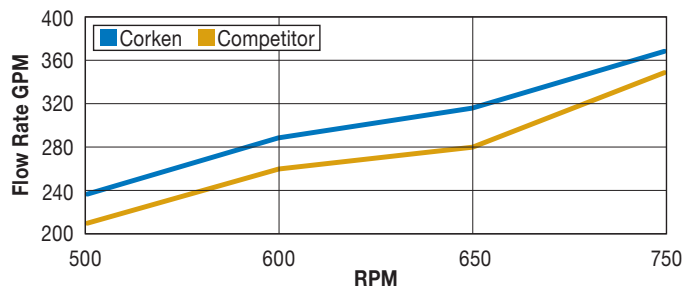

RPM	500	600	650	750
Corken gpm (L/min)	236 (893)	289 (1,094)	316 (1,196)	369 (1,397)
Competitor gpm (L/min)	210 (795)	260 (984)	280 (1,060)	350 (1,325)

\* All capacities are rated at 50 psid and system and condition dependent.

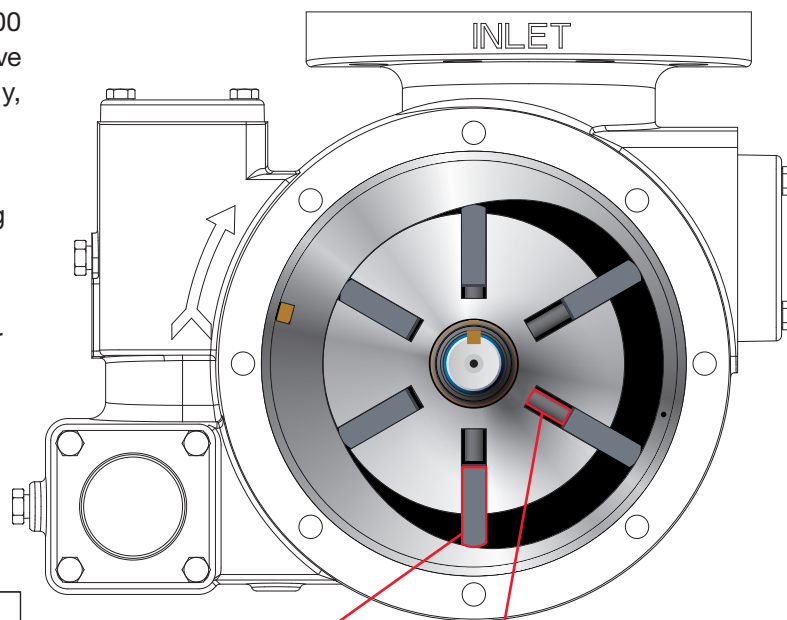

#### Leading Edge of Vane Has 2X the Thickness:

- Extends vane life
- Improves durability

#### Improved Vane Driver Material:

- 60% stronger
- Increased wear resistance and durability

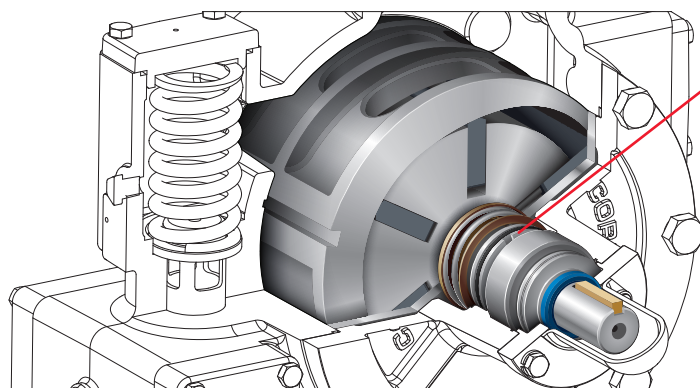

#### Silicon Carbide Seal Seat:

- Maximizes sealing performance and durability
- Requires less maintenance

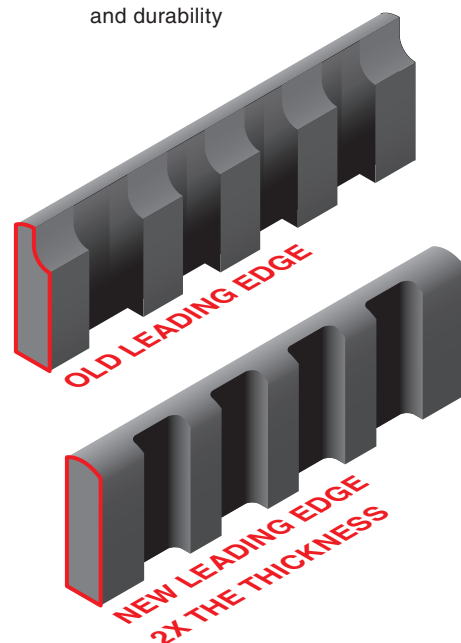

Solutions beyond products...

# CORKEN®

CORKEN, INC. • A Unit of IDEX Corporation  
 9201 North I-35 Service Road, Oklahoma City, OK. 73131 U.S.A.  
 Phone (405) 946-5576 • FAX (405) 948-7343  
 Visit our website at [www.corken.com](http://www.corken.com)  
 E-mail us at [cocsalesdept@idexcorp.com](mailto:cocsalesdept@idexcorp.com)



@CorkenInc

