

INDUSTRIAL CORO-FLO® PUMPS

Sales Bulletin VF104G

TYPICAL APPLICATIONS

Reflux pump for gas liquids
LP-Gas vaporizer feed pump
Aerosol propellant pump
Anhydrous ammonia
cylinder filling
Propane motor fuel pumping

Pumps 2 to 36 gpm (7.6 to
136 L/min)

Heads to 700 ft (213 m)

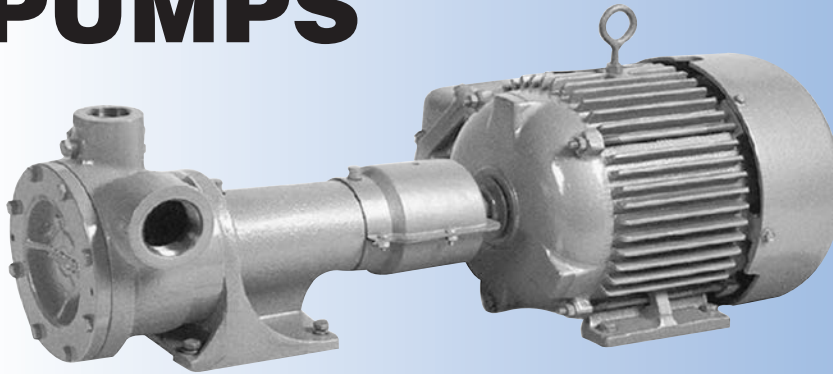

MODEL F14-101

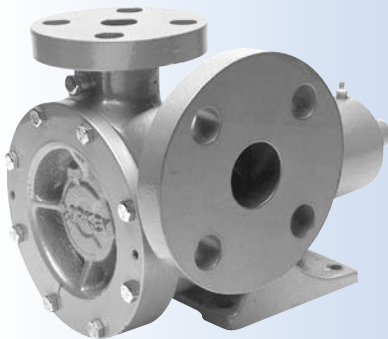

**F-MODEL WITH
ANSI FLANGES**

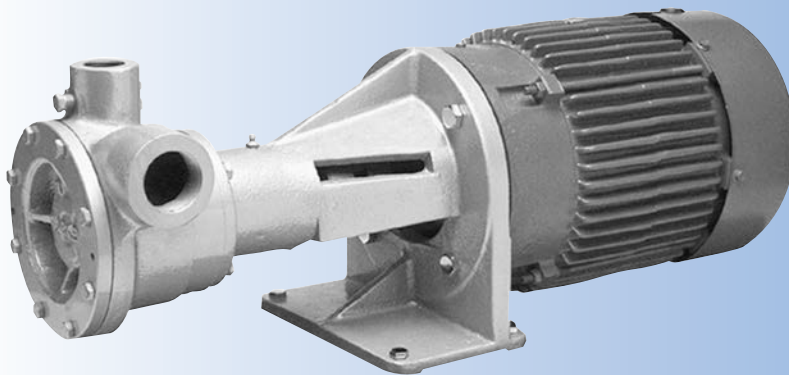

DS/DL MODEL

FOR THIN LIQUIDS & LIQUEFIED GASES

Propane
Butane
Ammonia
Refrigerants
Sulfur Dioxide
Carbon Dioxide
Gasoline
Light Oils
Solvents
Propylene
Pentane
Foam Blowing Agents



Listed by Underwriters'
Laboratories, Inc. for use
in LP-Gas and
Anhydrous Ammonia.

Solutions beyond products...

 **CORKEN**
IDEX

THE CORKEN CORO-FLO PUMP - 'F' SERIES

IDEAL FOR RESEARCH LABORATORY WORK AND FOR HANDLING MANY LIQUIDS OF THE PETROCHEMICAL, LPG, NH₃ AND AEROSOL INDUSTRIES.

For low-capacity, high-head pumping, the Corken Coro-Flo pump is designed and built for the tough jobs. Without the noise, vibration and pulsations of the positive displacement gear and sliding vane pumps, the Coro-Flo pump handles volatile and other hard-to-handle thin liquids smoothly and quietly. The one moving part, the impeller, floats on the shaft with no rubbing, grinding or metal-to-metal contact.

The Corken Coro-Flo was originally developed to fill propane cylinders, but it has found its way into many other fields, especially where volatile liquid transfer is involved. It is commonly used to feed aerosol filling lines, and to transfer liquefied gases like NH₃, CO₂, SO₂ and the refrigerant gases.

The Coro-Flo pump has been designed for simplicity of inspection and service. The cover can be removed and the impeller and seal serviced without disturbing the piping. The balanced mechanical seal is furnished with its own sleeve for the longest and most reliable service.

Every Corken Coro-Flo pump is carefully inspected and run to assure its quality and performance. The Coro-Flo is listed by Underwriters' Laboratories, Inc. for use in LP-Gas and anhydrous ammonia service.

MATERIAL SPECIFICATIONS

Part	Standard	Optional
CASE/COVER	Ductile Iron ASTM A-536	None
IMPELLER	Bronze	303 Stainless Steel Ductile Iron
SHAFT	Stressproof Steel	416 Stainless Steel
O-RINGS	Buna-N	PTFE Viton ^{®1} Neoprene ^{®1} Ethylene-Propylene
SEAL SLEEVE	Aluminum	416 Stainless Steel
SEAL SEAT	Cast Iron	304 Stainless Steel Ni-Resist Ceramic Tungsten Carbide
SEAL HOUSING	Steel, Cadmium Plated	416 Stainless Steel

MECHANICAL SPECIFICATIONS

INLET	1-1/4" NPT (Models F9, F10)
	1-1/2" NPT (Models F12, F13, F14, F15)
	1-1/2" ANSI 300 LB. (Models FF9-FF15)
OUTLET	1" NPT
	1" ANSI 300 LB. (FF9-FF15)
ROTATION	Clockwise only (From driven end)
MAX. RPM	3600
MAX. CASE TEST PRESSURE	2500 psig (172 Bar)
MAX WORKING PRESSURE	400 psig (27.6 Bar)
MAX DIFFERENTIAL PRESSURE	125 psig (10.3 Bar)
HORSEPOWER RANGE	1/2 to 10
TEMPERATURE RANGE	-25° to +225° F (-32° to +107°C)
MAX. VISCOSITY	400 SSU

¹ Registered trademarks of the DuPont Company.

PERFORMANCE CURVE - 3450 RPM*

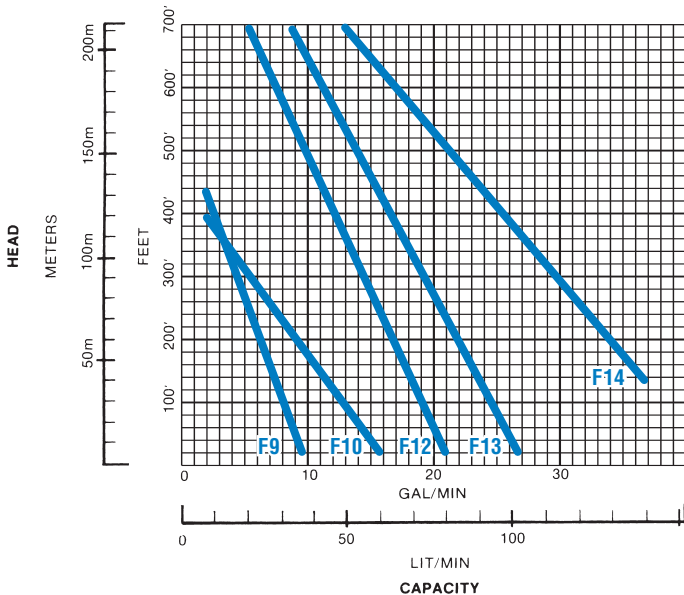

PERFORMANCE CURVE - 2880 RPM*

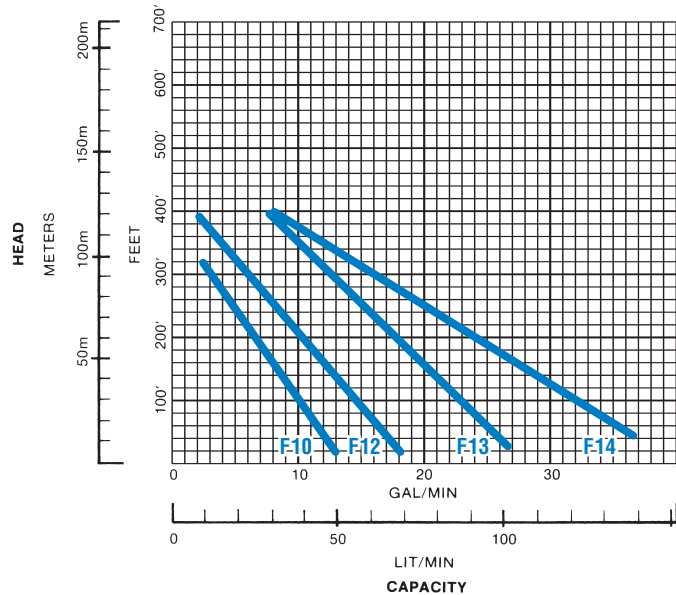

*Curves based on water.

EXCLUSIVE FEATURES OF THE CORO-FLO PUMP

EXCLUSIVE DIVIDED SUCTION DESIGN provides smooth continuous flow through the pump.

A BY-PASS CONNECTION, 3/4" pipe thread, has been located on the outlet nozzle to simplify piping of the pump.

A PRESSURE GAUGE CONNECTION, 1/4" pipe thread, has been located on the outlet nozzle.

UNDERWRITERS' LABORATORIES, INC has tested and inspected CORO-FLO PUMPS and has listed them for use in the handling of L.P. Gas and Anhydrous Ammonia Liquid.

THE BALANCED MECHANICAL SEAL ASSEMBLY with its own shaft sleeve may be replaced easily by removing the Cover and the Impeller without disturbing the piping or driver. No special tools are needed.

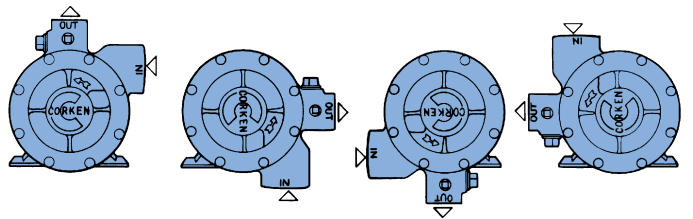
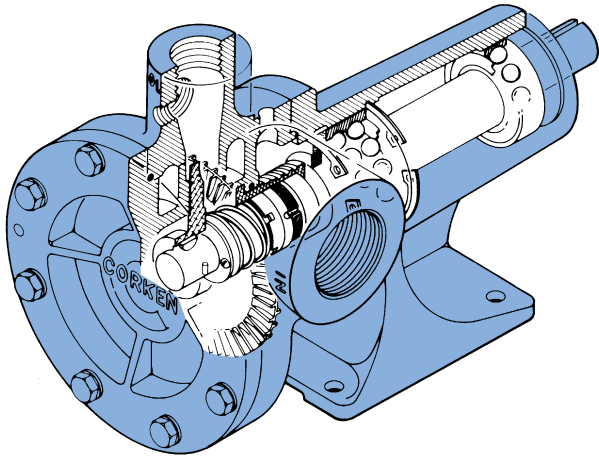

THE IMPELLER "floats" on the shaft and may be replaced easily when worn or damaged by simply removing the Cover without disturbing the piping.

HEAVY-DUTY BALL BEARINGS are used for precision operation and long service life.

RUGGED DUCTILE IRON has been used in the manufacture of this pump for parts under pressure of the liquid.

THE PUMP NOZZLES MAY BE ROTATED into four different positions, 90 degrees apart, if desired.

300 LB. ANSI FLANGES are also available for those applications requiring stringent leakage control.

FOR LP-GAS APPLICATIONS ONLY

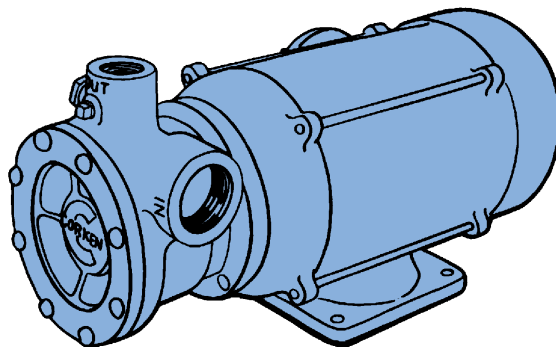

Close-Coupled Pump Motor units are available.
See Corken Bulletin LPG100.

AN IMPORTANT ACCESSORY TO THE CORO-FLO PUMP CORKEN B166 BY-PASS VALVE

Automatic, Dual Purpose By-pass Valve

This is a combination by-pass and priming valve specifically designed for small bottle filling pumps, such as the Corken Coro-Flo pump series. The patented vapor elimination systems keep liquefied gas pumps primed to increase system reliability and decrease pump and seal wear. The B166 is a smooth operating by-pass with moderate pressure build up.

Corken B166 Bypass Valve Functions.

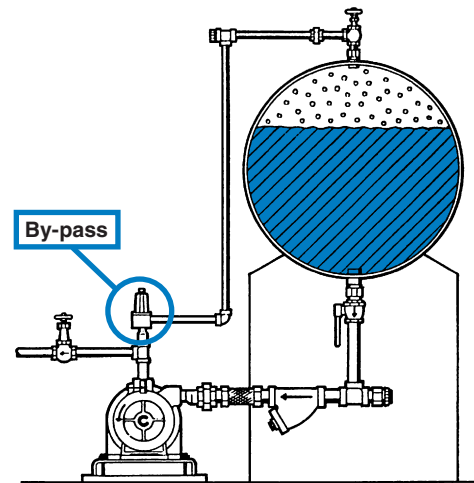
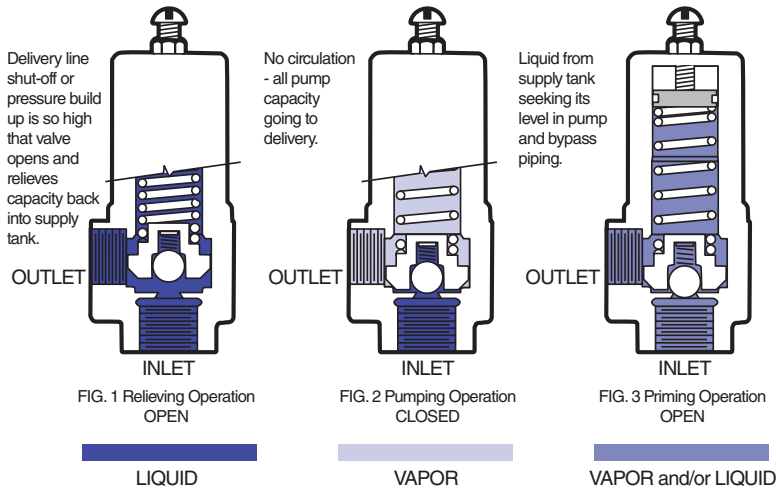

Typical Application: On all Corken Coro-Flo pumps as well as bottle pumps of other manufacturers. On propellant feed pumps at aerosol filling plants.



Corken, Inc. • A Unit of IDEX Corporation

9201 North I-35 Service Road, Oklahoma City, OK. 73131 U.S.A.
Phone (405) 946-5576 • FAX (405) 948-7343

Visit our website at <http://www.corken.com>
E-mail us at info.corken@idexcorp.com