

# Z4500 Stationary Pump

Reduces Fill Times Saving Time and Money

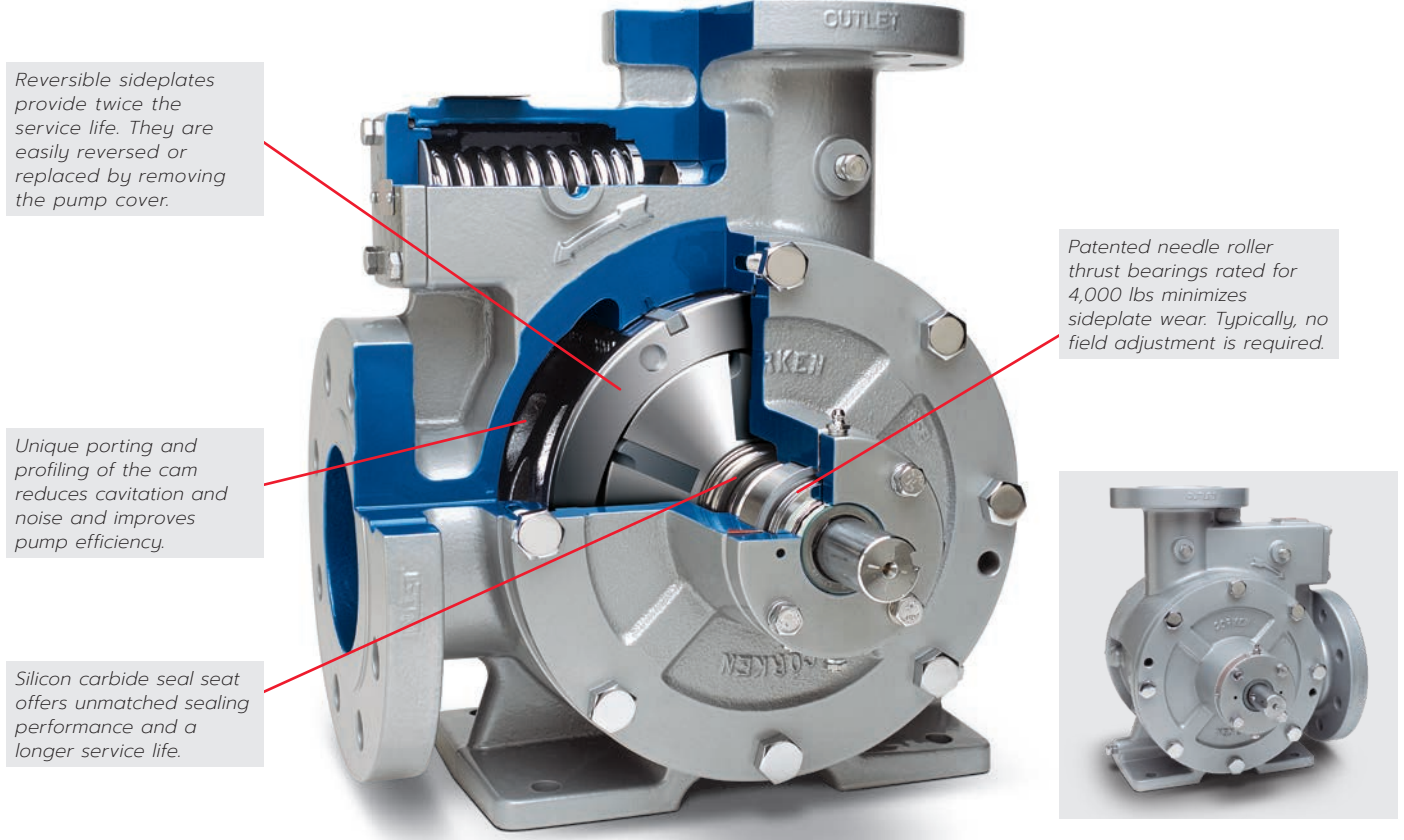

Reversible sideplates provide twice the service life. They are easily reversed or replaced by removing the pump cover.

Patented needle roller thrust bearings rated for 4,000 lbs minimizes sideplate wear. Typically, no field adjustment is required.

Unique porting and profiling of the cam reduces cavitation and noise and improves pump efficiency.

Silicon carbide seal seat offers unmatched sealing performance and a longer service life.

## Higher capacities shorten loading times for transport and multi-bobtail applications...

The Z4500 is a four-inch stationary pump designed for loading transports and multiple bobtails. It's ideal for applications using two or more bulkheads. At typical operating RPMs, the Z4500 can fill two 3,000 gallon bobtails in twenty minutes or less.

speed sensitive allowing the pump to operate at higher RPMs without causing damage.

Other advantages:

- Advanced material specification for cam and blades extends the service life.
- Unique porting and profiling of the cam reduces cavitation and noise and improves pump efficiency.

- Unlike competitive pumps restricted to 640 RPM, the Z4500 can operate up to 800 RPM.
- Offers up to 15% more flow than competitive pumps at typical operating conditions.
- Silicon carbide seal seat offers unmatched sealing performance and a longer service life.
- Large diameter, non-metallic vane drivers are not

	Capacity Comparison <sup>1</sup>			
	RPM			
	420	520	640	780
Corken gpm (L/min)	197 (746)	248 (939)	309 (1,170)	382 (1,446)
Competitor gpm (L/min)	170 (643)	220 (833)	270 (1,022)	—

<sup>1</sup> All capacities are rated at 50 psid and system and condition dependent.

## Operating Specifications

RPM range:	420–800 RPM
Max working pressure:	350 psig (24.1 bar g)
Temperature range:	-25°F–225°F (-32°C–107°C)
Internal relief valve:	Yes
Max differential pressure:	125 psid (8.6 bar d)
Flow range:	190–382 gpm (719–1,457 L/min)

## Performance Curves at 640 RPM

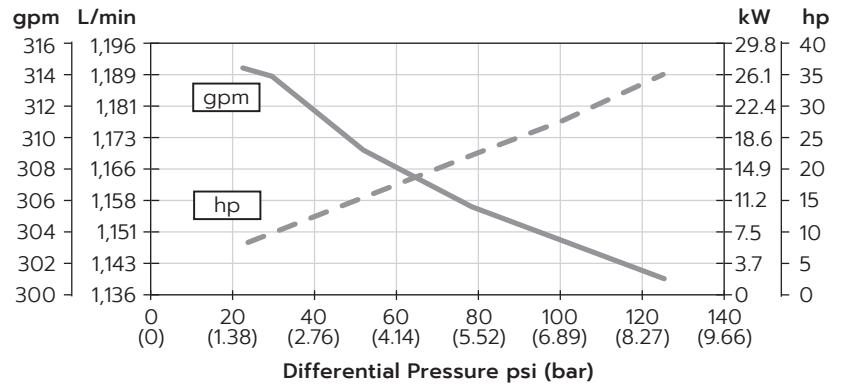

## Material Specifications

Part	Standard Material	Optional Material
Case, head, rotor, relief-valve cap, bearing cap	Ductile iron ASTM A536	
Cam	Gray iron ASTM A48, Class 50	
Sideplate	Gray iron ASTM A48, Class 30	
Welding flange	Steel	
Seal seat	Gray iron	Stainless steel and Ni-Resist
Seal metal parts	Steel	
Shaft	8620 steel	
Vanes and vane drivers	Advanced polymers	
Relief valve spring	Stainless steel	
Relief valve	Stainless steel	
Bearing	Steel	
Thrust bearing	Steel	
O-rings	Buna-N	PTFE, Viton <sup>®1</sup> , Neoprene <sup>®1</sup>
Retainer rings	Steel	

<sup>1</sup>Registered trademark of the DuPont company.

## Outline Dimensions

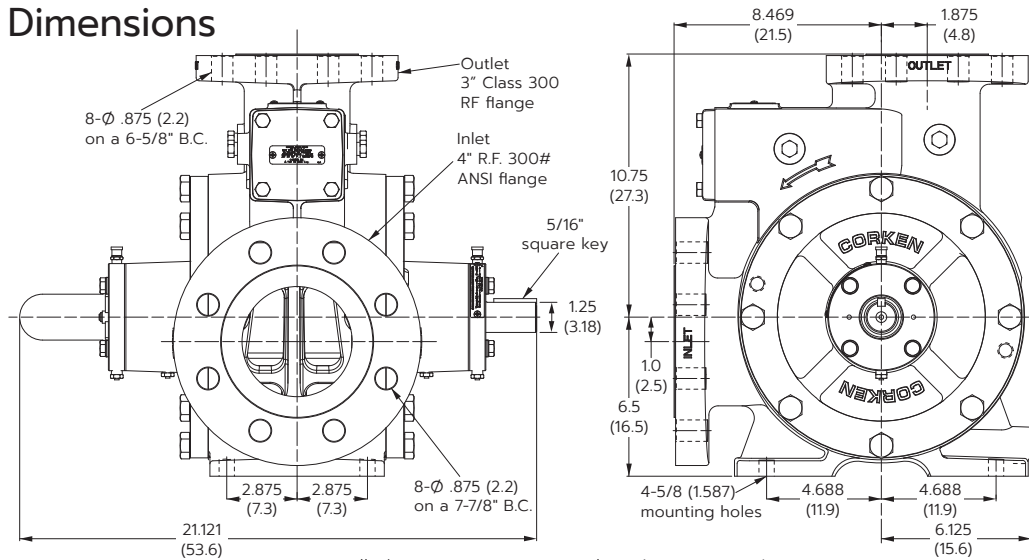

All dimensions are in inches (centimeters).

Solutions beyond products...

# CORKEN<sup>®</sup>

CORKEN, INC. • A Unit of IDEX Corporation  
 9201 North I-35 Service Road, Oklahoma City, OK. 73131 U.S.A.  
 Phone (405) 946-5576 • FAX (405) 948-7343  
 Website: www.corken.com • E-mail: cocsalesdept@idexcorp.com



@CorkenInc

