

# ZV200 Bypass Valve

A Two-inch Bypass Valve for Truck and Stationary Applications

Notched cap over adjustment screw: Provides tamper-proof wiring feature to ensure the valve remains set by authorized personnel in the field.

Square head adjustment screw: Allows for easy field adjustment.

Multiple spring options: 41–70, 71–90, 91–125, and 126–150 psig differential range.

Corrosion resistant stainless steel internal valve: Increases durability and minimizes wear extending the life of the valve.

Dual inlet and outlet gauge openings: Provide greater flexibility for mounting pressure gauges or a hydrostatic relief valve without adding a “Tee”, “Weld-o-let” or special opening.

Multiple flange options: 1.25", 1.5", 2", 2.5" NPT and weld flanges. No unions necessary for installation.

## Low pressure build-up bypass valve for truck and stationary applications.

The two-inch ZV200 is a low pressure build-up bypass valve designed for applications requiring protection for positive displacement pumps. Specifically designed for protecting pumps with capacities up to 250 gpm (946 L/min). The continuous internal bleed will assist in the operation of systems with “air” or “electric” operated internal valves. Typical applications include bobtail, transport and stationary loading and unloading of LPG, NH<sub>3</sub> and other light liquids.

- Dimensionally interchangeable with commonly used two-inch bypass valves; no need to change piping configuration.
- Ductile iron construction offers maximum strength for higher pressures.
- Flow rates up to 250 gpm (946 L/min) at 120 psi (8.3 bar) differential.
- Continuous bleed helps equalize pressure to assist remote operated internal valves.
- Multiple spring options enable you to select the pressure required for your truck or stationary application.

*Solutions beyond products...*

 **CORKEN**  
IDEX

## Operating Specifications

<b>Maximum differential pressure:</b>	150 psid (10.34 bar)
<b>Operating temperature range:</b>	Up to 225°F (107°C) <sup>1</sup>
<b>Maximum working pressure:</b>	400 psi (27.6 bar)
<b>Spring ranges:</b>	91–125 psi (6.3–8.6 bar) standard 41–70 psi (2.8–4.8 bar) optional 71–90 psi (4.9–6.2 bar) optional 126–150 psi (9.0–10.3 bar) optional

<sup>1</sup>Fitted with Buna-N O-rings.

## Performance

Differential Pressure psi (bar)	Maximum Rated Flow for Propane gpm (L/min)
70 (4.82)	180 (681)
120 (8.27)	250 (946)

## Material Specifications

Part	Material
Adjustment nut cap	ASTM A536 65-45-12
Adjusting screw	Steel
Bypass valve body	Ductile iron: ASTM 536, 60-40-18
Bypass valve cap	Ductile iron: ASTM 536, 60-40-18
Gasket	1010 hot rolled steel
Flanges	Ductile iron: ASTM 536, 65-45-12 (standard) Plate steel: ASTM A516 (optional weld)
O-rings	Viton® (standard) <sup>2</sup> Buna-N, Neoprene®, EPDM, PTFE, Kalrez® (optional) <sup>2</sup>
Spring	Music wire/chrome silicon
Spring guide	8620 A322 ASTM steel
Relief valve	17-4 PH stainless steel

<sup>2</sup>Viton®, Neoprene®, and Kalrez® are a registered trademarks of the DuPont company.

## ZV200 Outline Dimensions

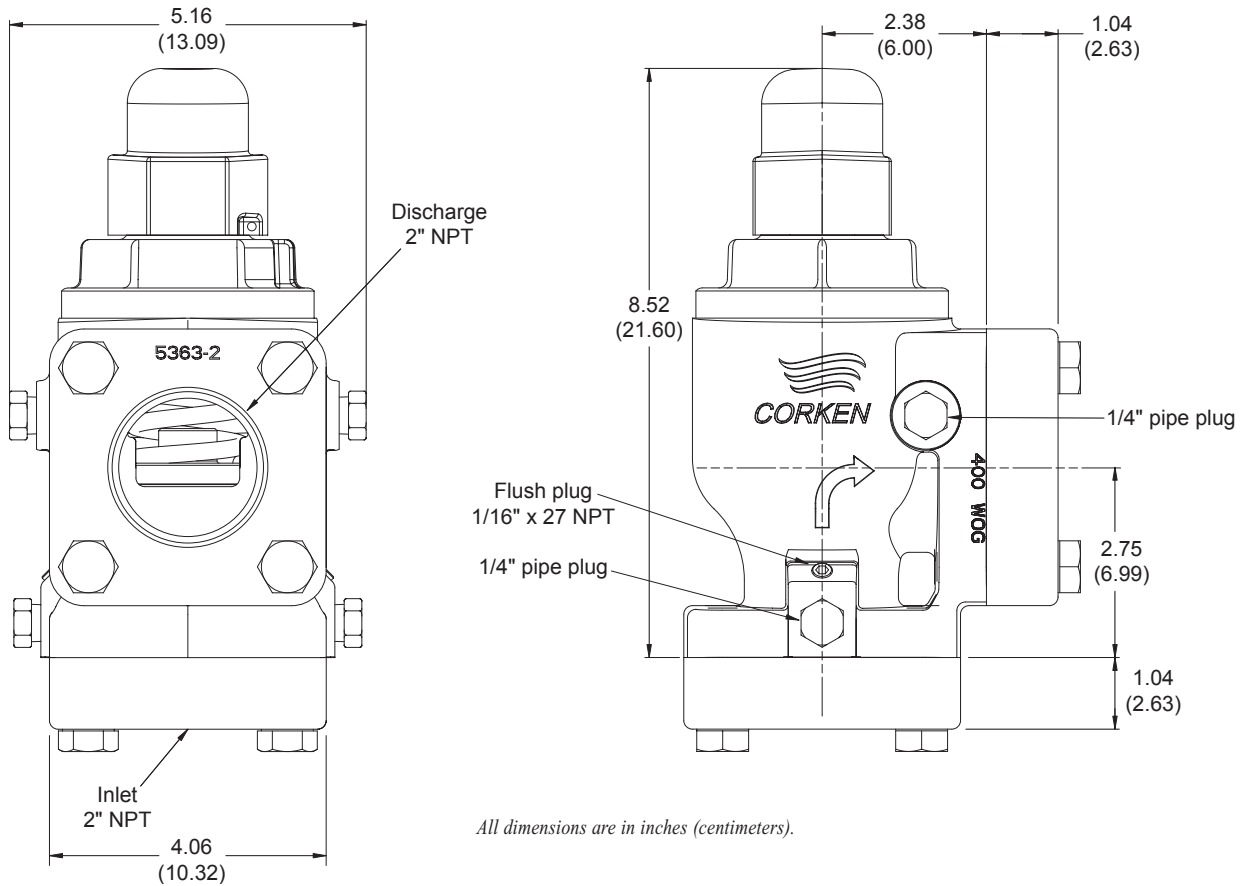

All dimensions are in inches (centimeters).

QUALITY  
**ISO 9001**  
SYSTEM

Solutions beyond products...  
**CORKEN**  
IDEX

ENVIRONMENTAL  
**ISO 14001**  
MANAGEMENT  
SYSTEM

Corken, Inc. • A Unit of IDEX Corporation  
9201 North I-35 Service Road, Oklahoma City, OK. 73131 U.S.A.  
Phone (405) 946-5576 • FAX (405) 948-7343

Visit our website at <http://www.corken.com> • E-mail us at [info.corken@idexcorp.com](mailto:info.corken@idexcorp.com)