

# European Union Addendum

---

## For Corken's Gas Compressors—All Models



Model WFD591 Compressor



Model 491 Compressor

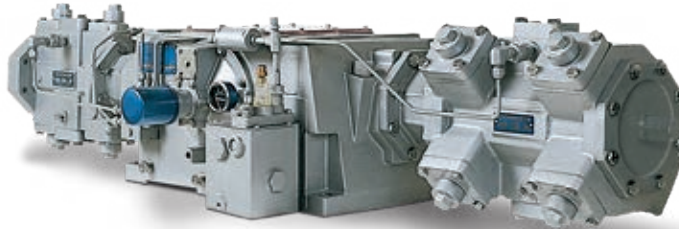

Model HG602 Compressor



Model T891 Compressor

**This Addendum Covers the Following European Union Directives:**

**Machinery Directive 2006/42/EC  
and  
ATEX Directive 2014/34/EU**

**Applies to Corken Installation, Operation & Maintenance (IOM)  
Manuals with the following document numbers:**

**IE100, IE101, IE105, IE106, IE107, IJ100, and IJ110.**

Warning: (1) Periodic inspection and maintenance of Corken products is essential. (2) Inspection, maintenance, and installation of Corken products must be made only by experienced, trained, and qualified personnel. (3) Maintenance, use, and installation of Corken products must comply with Corken instructions, current applicable laws, and safety standards. (4) Transfer of toxic, dangerous, flammable, or explosive substances using Corken products is at user's risk and equipment should be operated only by qualified personnel according to applicable laws and safety standards.

---

*Solutions beyond products...*

**CORKEN®**

---

# Table of Contents

**General Description . . . . . 3**

**EU Declaration of Conformity and Declaration of Incorporation for Machinery Directive . . . . . 4**

**Labeling/Safety . . . . . 5**

**Specification Section . . . . . 5**

**Installation / Incorporation Section . . . . . 9**

---

This addendum applies to all of Corken's gas compressors using Installation, Operation, and Maintenance (IOM) manuals with the following document numbers:

**IE100, IE101, IE105, IE106, IE107, IJ100, and IJ110 .**

**This document number is located in the upper right-hand corner of the front cover.**

This addendum to Corken gas compressor Installation, Operating, and Maintenance (IOM) manuals provides additional information required under the European Union Machinery Directive 2006/42/EC for Compressors and ATEX Directive 2014/34/EU.

## Manufacturer

**Corken, Inc.**  
9201 North I-35 Service Road,  
Oklahoma City, OK 73131  
U.S.A.

## General Description

Corken gas compressors are reciprocating compressors for use with a variety of industrial gases. Corken has a line of vertical compressors built in single- and two-stage versions, both single- and double-acting. Corken also has a line of double-acting horizontal compressors built in single- and two-stage versions with a choice of cylinder sizes.

Corken gas compressors have a large selection of construction variations. Listed below are a few examples.

- Packing variations depend on operating conditions
- An external lubricator when it is desired to lubricate the cylinder(s)
- Compressor valve variations including:
  - Liquid relief suction valves
  - Valve spring variations depending on pressure conditions
  - Valve coating and material variations depending on the gas being handled and other conditions that can affect wear
- Piston ring material options
- Metal valve gasket material options
- O-ring material options
- On two-stage machines, intercooler material options
- Flywheel size options
- Protective coating options
- Piston rod material options
- Adjustable head option on some cylinder sizes

**EU DECLARATION OF CONFORMITY FOR ATEX DIRECTIVE 2014/34/EU &  
DECLARATION OF INCORPORATION FOR MACHINERY DIRECTIVE 2006/42/EC**

<b>Issue Details:</b>	<b>Date:</b>	<b>Place:</b> Oklahoma City, OK, USA	<b>DoI Number:</b>
<b>Conforming: "Partly Completed Machinery"</b>	<b>Compressor Series D, FD, T, FT, WD, WFD, WFT, HG, THG, WG, F models 91 thru 891 and 601 thru 604 with cylinder sizes 2-3/4" (69.8mm) to 8" (203.2mm) for Ammonia, LPG, &amp; Industrial Gases.</b>		
<b>Model:</b>	<b>Serial No(s):</b>	<b>Date of Manufacture (MM/YYYY):</b> -- / ----	
<b>Manufacturer:</b>	<b>Corken Inc, 9201 North I-35 Service Road, Oklahoma City, OK. 73131, USA</b>		
<b>Machinery Directive 2006/42/EC</b>			
<b>Person, established within the Community, responsible for compiling the Technical Documentation:</b>	Andrea Puccini, Engineering Manager SAMPI S.p.A, Via A. Vespucci, 1 55011 Altopascio-Italy		
<b>Harmonised Standards &amp; Other Technical Standards/Specifications Applied or Referenced:</b>	BS EN 809:1998+A1:2009, BS EN ISO 14120: 2015, BS EN ISO 12100:2010, BS EN 12162:2001+A1:2009, BS EN ISO 13732-1:2008, BS EN ISO 13857:2019, BS EN 61310-1:2008, BS EN 61310-2:2008, BS EN 61310-3:2008		
<b>We hereby declare that the partly assembled machinery described above must not be put into service until the final machinery into which it is to be incorporated has been declared in conformity with the provisions of Directive 2006/42/EC on machinery.</b>			
<b>ATEX Directive 2014/34/EU</b>			
<b>ATEX Classification</b>	Group II Cat 2G Ex h IIB TX Gb		
<b>Harmonized Standards &amp; Other Technical Standards/Specifications Applied: Technical Documentation</b>	BS EN ISO 80079-36:2016, BS EN ISO 80079-37:2016		
	Technical Dossier: CTF1-A, Issue 5 Held by: DNV GL Presafe Certification AS (NB #2460) Veritasveien 3 NO-1363 Hovik Norway Tel +47 67 57 8800 Acknowledgement #: 13717-2018-CE-USA-PRE X		
We declare that the machinery described above conforms with the essential health and safety requirements of Directive 2014/34/EU concerning equipment and protective systems intended for use in potentially explosive atmospheres. This declaration is issued under the sole responsibility of the manufacturer.			
<b>PED 2014/68/EU</b>			
Equipment is excluded from the Scope of the Pressure Equipment Directive (PED) 2014/68/EU under Article 1.2.j.ii			
<b>Signed:</b>			
<b>Signatory: .</b>			

# Labeling/Safety

The following warning labels are affixed to Corken gas compressors as indicated:



General danger label IS6014 is affixed on a visible surface. (Black on yellow background)



Hot surface burn hazard label IS6043 is affixed on surfaces above 50°C including the head, cylinder and crosshead guide. (Black on yellow background)



Read operators manual label IS6017 is affixed on a visible surface. Corken gas compressors should not be installed, started or operated before reading the Installation, Operation & Maintenance (IOM) manual provided with the compressor and this addendum to the IOM manual. (White on blue background)



Lifting point label IS6183 is affixed on adjacent to the lifting eyes on horizontal compressors only. (White on blue background)

# Specification Section

One of the following Corken nameplates is attached to the compressor:

Corken gas compressor nameplates include the following information:

- Identification of Corken as the manufacturer with address
- Model number
- Serial number
- Crankcase oil capacity in quarts (liters)
- Statement to “READ Corken INSTRUCTION MANUAL BEFORE OPERATING”
- ATEX rating: II 2G Ex h IIB TX Gb
- Acknowledgement number: 13717-2018-CE-USA-PRE X

Vertical Compressor Nameplate Sample

Supplemental Compressor

- MAP rating (Maximum Allowable Pressure allowed at the outlet in bar (gauge))
- MAX RPM rating (Maximum rotational speed allowed, in RPM)
- GROSS MASS (mass of the compressor in kg)
- IOM document number
- Date of manufacturing (The month and year the compressor was built)

Horizontal Compressor Nameplate Sample

## Operating and Storage Temperature Ranges

Recommended storage temperature range: -32°C to 54°C

Recommended storage humidity range: < 80%

Recommended storage altitude range: No Limitations

## Inlet, Intermediate, and Discharge Temperatures

Inlet, intermediate and discharge operating temperatures vary with the gas being handled, the compression ratio, compressor speed, type of coolant and coolant flow rate. The type and size of intercoolers on two-stage machines are also factors. The minimum suction temperature allowed is -32°C. The maximum allowable discharge temperature at any location on all Corken compressors is 177°C.

## Inlet and Discharge Pressures

Inlet and discharge pressures vary with the compressor model and are shown in the following tables:

### Vertical Compressors

Single-Stage Vertical Models	Minimum Inlet Pressure (Bars absolute)	Maximum Outlet Pressure (Bars gauge)
91, D91, F91, T91, FD91, FT91	0.21	23.1
291, D291, F291, T291, FD291, FT291	0.21	23.1
491, D491, F491, T491, FD491, FT491	0.21	23.1
491-3, D491-3, F491-3, T491-3, FD491-3, FT491-3	0.21	41.4
691, D691, F691, T691, FD691, FT691, WFD691, WFT691	0.21	23.1
691-4, D691-4, F691-4, T691-4, FD691-4, FT691-4, WFD691-4, WFT691-4	0.21	41.4
D891, FD891, T891, FT891	0.21	31.0

Two-Stage Vertical Models*	Minimum Inlet Pressure (Bars absolute)	Maximum Outlet Pressure (Bars gauge)
191, D191, F191, T191, FD191, FT191	0.21	41.4
FD151, FT151	0.21	82.7
391, D391, F391, T391, FD391, FT391, WD391, WT391, WFD391, WFT391	0.21	41.4
WFD351, WFT351	0.21	82.7

Two-Stage Vertical Models*	Minimum Inlet Pressure (Bars absolute)	Maximum Outlet Pressure (Bars gauge)
FD591, FT591, WFD591, WFT591	0.21	41.4
WFD551, WFT551	0.21	68.9
D791, T791	0.21	41.4

\* Two-stage compressors have an interstage section with an interstage pressure at a level between that of the inlet pressure and the outlet pressure.

## Horizontal Compressors

The minimum inlet pressure for a horizontal compressor is approximately atmospheric.

The maximum pressure for horizontal compressors is determined by the cylinder size:

Horizontal Compressor Cylinder Size In (mm)	Cylinder Code Letter	Maximum Allowable Working Pressure, (Bars gauge)
8 (203.2)	A	20.7
6 (152.4)	B	24.1
5 (127.0)	C	51.7
4 (101.6)	D	68.9
3.25 (82.55)	E	82.7
2.75 (69.85)	F	113.8

NOTE:

- 1) Single-stage horizontal compressors begin with HG601 or THG601 and do not have an interstage section and therefore no intermediate pressure.
- 2) Two-stage horizontal compressors begin with HG602 or THG602 and have an interstage section with an intermediate pressure at a level between that of the inlet pressure and the outlet pressure.

## Maximum Pressure (Compression) Ratio

Maximum compression ratio varies with the compressor model and is shown in the following table:

Vertical Compressor Models	Minimum Compression Ratio	Maximum Compression Ratio – Continuous Duty	Maximum Compression Ratio – Intermittent Duty
All Single-Stage Compressors	—	5	7
191, D191, F191, T191, FD191, FT191	5	10	35
FD151, FT151	5	10	35

Vertical Compressor Models	Minimum Compression Ratio	Maximum Compression Ratio – Continuous Duty	Maximum Compression Ratio – Intermittent Duty
391, D391, F391, T391, FD391, FT391, WD391, WT391, WFD391, WFT391	5	10	35
WFD351, WFT351	5	12	35
FD591, FT591, WFD591, WFT591	5	12	25

*NOTE: Both single- and two-stage compressors should be operated so that their maximum temperature does not exceed 177°C.*

### ATEX Requirements and Ratings

These products are classified under the ATEX directive as Equipment – Group II – category 2 – equipment that is intended for use in areas where explosive atmospheres caused by gases or vapors (G) may be present.

ATEX rating: II 2G Ex h IIB TX Gb, where X represents the digit corresponding to the temperature code. This code is dependent on the maximum surface temperature.

The maximum surface temperatures reached on the compressor is directly related to the discharge temperature of the process gas. Factors which will affect the discharge temperature of the process gas include, but are not limited to the following:

1. The physical properties of the process gas
2. The compression ratio of the process
3. The temperature of the process gas entering the compressor
4. The elevation (above sea level) of the process location

**Notice: If necessary, contact Corken for assistance predicting the discharge temperature of the process. If any of the four items listed above change, the discharge temperature might rise to unacceptable levels.**

**Important Installation Requirements:** The use of one (or more) temperature sensing devices, which output either continuous discharge temperature readings, or a discreet signal when the discharged process gas reaches a pre-set temperature, are required to control the maximum allowable discharge temperature of the process.

**Note:** The surface temperature of the head and cylinder will be slightly less than the discharge temperature of the process gas, and will lag behind the rising discharge temperature of the process gas.

The temperature rating should be as follows:

1. The **pre-set temperature** of the high discharge temperature switch (HDT). This safety switch must be used by the control system to **automatically stop the compressor** when the process discharge temperature reaches the set-point.
2. The **set-point in the control system** which will **automatically stop the compressor** when the temperature reading from the temperature sensor reaches the pre-set value.

### Machine Mass

The machine mass varies with the compressor model and is shown in the following tables:

Vertical Compressor Model	Machine Mass (kg)	Vertical Compressor Model	Machine Mass (kg)
91	52	T491	217
D91	68	FD491	177
F91	52	FT491	217
T91	75	491-3	118
FD91	68	D491-3	177
FT91	75	F491-3	118
191	76	T491-3	217
D191	98	FD491-3	177
F191	76	FT491-3	217
T191	112	D590	359
FD191	98	T590	378
FT191	112	FD591	359
FD151	98	WFT591	378
FT151	112	WFD551	359
291	73	WFT551	378
D291	95	691	284
F291	73	D691	338
T291	109	F691	284
FD291	95	T691	357
FT291	109	FD691	338
391	100	FT691	357
D391	159	691-4	284
F391	100	D691-4	338
T391	201	F691-4	284
FD391	159	T691-4	357
FT391	201	FD691-4	338
WD391	159	FT691-4	357
WFD391	159	WF691	302
WT391	201	WFD691	356
WFT391	201	WFT691	375
FD351	154	WF691-4	302
FT351	195	WFD691-4	356
WFD351	159	WFT691-4	375
WFT351	201	D791	422
491	118	T791	467
D491	177	D891	408
F491	118	T891	454

Horizontal Compressor Model	Machine Mass (kg)	Horizontal Compressor Model	Machine Mass (kg)
HG601AX	331	THG601AX	354
HG601BX	295	THG601BX	318
HG601CX	290	THG601CX	313
HG601DX	286	THG601DX	308
HG601EX	281	THG601EX	304
HG601FX	281	THG601FX	304
HG601AA	485	THG601AA	531
HG601BB	413	THG601BB	458
HG601CC	404	THG601CC	449
HG601DD	395	THG601DD	440
HG601EE	383	THG601EE	429
HG601FF	383	THG601FF	429
HG602AB	449	THG602AB	494
HG602AC	444	THG602AC	490
HG602AD	440	THG602AD	485
HG602AE	435	THG602AE	471
HG602AF	435	THG602AF	471
HG602BC	422	THG602BC	467
HG602BD	406	THG602BD	451
HG602BE	399	THG602BE	444
HG602BF	399	THG602BF	444
HG602CD	399	THG602CD	444
HG602CE	393	THG602CE	439
HG602CF	393	THG602CF	439
HG602DE	390	THG602DE	436
HG602DF	390	THG602DF	436
HG602EF	383	THG602EF	429

## Noise Level

The noise level generated by the compressor unit on its own is < 85 dB(A) at 1 meter.

End user must take all necessary precautions dependent on the noise levels generated by the complete system.

## Maximum Speed

The maximum speed varies with the compressor model and is shown in the following table:

Compressor Model	Maximum Speed (RPM)
F, D, T, W, 151, 191, 291, 351, 391, 491, 491-3, 591, 691, 691-4	825
D, FD, FT, T, 791, 891	900
HG601, HG602, THG601, THG602	1200
D, FD, FT, T, 91	800

## Other Warnings, Precautions, and Information

1. If end user **repaints** the compressor unit on incorporation they must ensure that all nameplates, warning labels and supplemental information stickers remain visible and legible.

2. Corken gas compressors are not to be used for pumping liquids.
3. Corken gas compressors are not to be used with the following process gases:
  - a. Acetylene
  - b. Fluorine
  - c. Nerve gases
  - d. Corrosive gases, without prior consultation with Corken
  - e. Oxygen
4. Most Corken gas compressor units are designed to be oil free. If an end user wishes to utilize the unit as an oil lubricated compressor at > 50 bar they must consult Corken.
5. End user to take all necessary precautions, including PPE, for their selected process gas e.g. hazardous, flammable, explosive, toxic, etc...
  - a. **Warning:** The risk of inhalation of harmful gases, mists and fumes exists.
  - b. **Warning:** Areas accessible to personnel may include concentration of process gases that can displace breathing air. These gases shall be kept within acceptable levels, in accordance with EN 12021 or current applicable code. Additional information regarding ventilation is included under point 3 of the Installation/Incorporation Section.
6. End user to take all necessary precautions for the selected crankcase oil – this must include reference to the MSDS/SDS and requisite PPE. Corken recommended oils are listed in the IOM manuals.
7. End user to take all necessary precautions for their selected coolant.
8. Only trained operators and maintenance technicians are to work on the system. Training for such personnel should include conventional training as a mechanic and additional training in the installation, operation and maintenance of reciprocating gas compressors. Gas compressor training is provided by Corken and many of its distributors.
9. Compressor unit is not to be accessed, adjusted, or maintained during operation. Unit must be isolated, depressurized, and immobilized before undertaking any such activities.
10. Inspection / access plates are only to be removed once the compressor unit is isolated, depressurized, and immobilized.

11. Do not climb on the machine.
12. Use access aids/step ladders when repairing or cleaning components out of reach.
13. PPE requirements for the various maintenance, adjustment and cleaning operations:
  - a. Fire protective clothing for compressor units used on flammable gases
  - b. Hard hat for head protection
  - c. Gloves as necessary
  - d. Eye protection
  - e. Steel-toed footwear
  - f. Hearing protection as necessary
14. If the end user is incorporating the compressor unit within a compressor system for outdoor use then the system must comply with the noise directive 2000/14/EC or the latest revision.
15. Precautions are to be taken to prevent ice and snow interfering with compressor unit operation when operating at ambient temperatures below 0°C.
16. **Warning:** Follow recommendations in acceptable oil products table in IOM manual. High oil viscosity during cold start up, clogged oil filters or valve malfunction can result in oil starvation and subsequent damage to the compressor unit.
17. A general description of Corken gas compressors is provided at the beginning of this addendum.
18. Safe lifting, transporting and handling:

a. Lifting vertical compressors

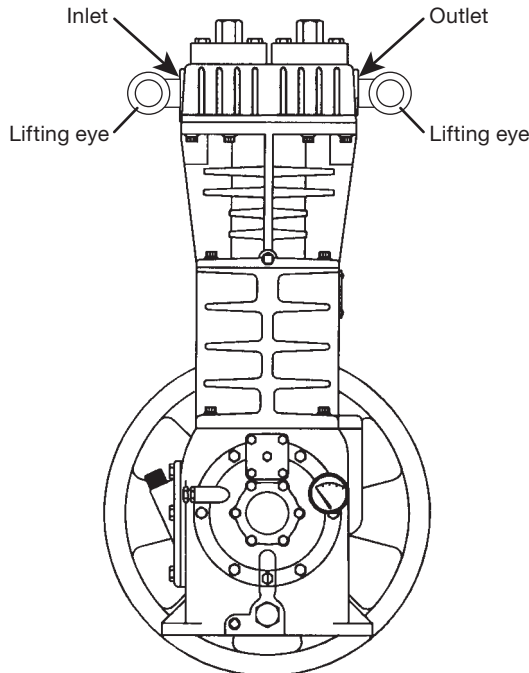

- i. Securely attach a lifting device, such as a lifting eye, in the inlet and outlet openings on the head of the compressor unit.
- ii. Connect a lifting apparatus, such as a hoist, forklift or sling, to the lifting device. End user must ensure the lifting apparatus has a load capacity at least as large as the weight of the compressor unit to be lifted.

b. Lifting horizontal compressors

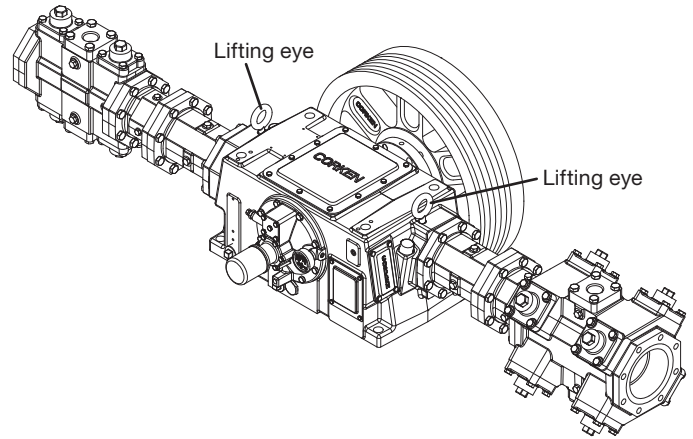

- i. Connect a lifting apparatus, such as a hoist, forklift or sling, to the lifting eyes on the crankcase of the compressor unit. End user must ensure the lifting apparatus has a load capacity at least as large as the weight of the compressor unit to be lifted.

- c. All compressor units should be securely bolted in a crate or on a pallet prior to transporting or otherwise handling the compressor unit away from the installation site.

19. Dismantling, assembling and installation:

- a. Instructions for dismantling, assembling and installing Corken gas compressors are provided in the IOM manual.
- b. When installing the compressor unit the end user must ensure it is properly anchored for stability by bolting it in position with bolts installed through all of the mounting holes in the feet of the crankcase. Use the largest size bolts that will fit through the mounting holes.

## Installation / Incorporation Section

### Installation (Incorporation) Requirements and Procedures

1. Detailed installation (incorporation) instructions including illustrated requirements and procedures are included in the IOM Manual.

- 
- a. The end user must provide suitable pressure relief for their system, within which the Corken compressor unit is incorporated, including:
    - i. The system suction pressure (if required)
    - ii. The system discharge pressure
    - iii. For multi-stage compressors, a pressure relief between stages
  - b. End user must guard the flywheel & external portion of the crankshaft in accordance with EN ISO 141208 2014 and EN 13857 or latest standard.
  - c. End user must ensure that the compressor unit is incorporated correctly within a compressor system that complies with all current relevant directives and standards including:
    - i. Machinery directive 2006/42/EC
    - ii. EN 1012-1, or latest standard, safety of compressors
    - iii. EN 60204-1 / -11, or latest standard, safety of electrical equipment for machines, as relevant
  - d. End user must provide suitable pressure indicators at the following locations:
    - i. Final outlet of compressor
    - ii. Pressure side of each separate stage of positive displacement compressors having a shaft input > 20 kW
    - iii. Inlet of a compressor having inlet pressure above atmospheric pressure
  - e. End user must ensure that the compressor unit inlet is not left open to atmosphere without suitable guarding such as an inlet filter or inlet check valve.
  - f. End user must ensure compressor units are grounded, via a metal base plate, in accordance with ATEX requirements and local regulations.
  - g. End user must take all necessary precautions on incorporation of the compressor unit within the system to prevent access to surfaces at hazardous touch temperatures, e.g. safeguarding.
  - h. End user must provide suitable pressure relief and control on heat exchanger circuits.
  - i. End user must incorporate the compressor unit in an ergonomic manner.
  - j. End user must ensure that there are no slip, trip, or fall hazards once the compressor is installed.
2. The maximum allowable discharge temperature for Corken compressors is 177°C.
    - a. The process (gas composition, compression ratio, gas suction temperature and elevation above sea level) must be suitable for the temperature rating selected.
    - b. Temperature limiting controls, such as high discharge temperature switches or temperature sensors transmitting continuous process gas discharge temperature information, are required to provide automatic shutdown functions if the discharge temperature of any stage increases beyond the expected operating temperature for the process at that point. The temperature sensing elements of these devices should be incorporated into the discharge piping of each stage as close to the compressor's discharge ports as possible.
    - c. As previously stated, the temperature rating of the compressor should be as follows:
      - i. The **pre-set temperature** of the high discharge temperature switch (HDT). This safety switch must be used by the control system to **automatically stop the compressor** when the process discharge temperature reaches the set-point.
      - ii. The **set-point in the control system** which will **automatically stop the compressor** when the temperature reading from the temperature sensor reaches that pre-set value.
      - iii. Under no circumstances should the maximum allowable operating temperature be set above 177° C.
  3. The packing should be properly vented or purged to provide the specified level of hazard reduction. The system designer and the end user are responsible for the proper implementation and use of the purge system. If a purge system is not used, a ventilation system capable of keeping the concentration of toxic or asphyxiating gases within acceptable levels per EN 12021 for the area should be provided. Failure to comply with this instruction will require use of PPE meeting Risk Category III under Regulation 2016/425 on Personal Protective Equipment.
  4. Corken compressors are not to be used to compress gases under any of the following conditions:
-

- 
- a. Any mixture between its lower explosive (or flammable) limit and upper explosive (or flammable) limit.
  - b. Any mixture or pure gas that will self-ignite without the addition of an oxidizer
  - c. Any mixture or pure gas that is reactive with the materials of the compressor
5. The system designer and end-user are responsible for taking all precautions necessary regarding the process, such as, but not limited to the following:
- a. Flammability, upper and lower limits
  - b. Toxicity, maximum safe concentration levels
  - c. Personal protective equipment requirements
  - d. Placard and signage requirements to comply with EN standards and other applicable codes
6. The drawings, diagrams, descriptions and explanations necessary for the use, maintenance and repair of the compressor unit and for checking its correct functioning are included in the IOM manual.

### Cleaning

1. Corken compressors should be cleaned with a non-toxic, non-flammable cleaning agent that is non-corrosive to iron. Most Corken compressor components are made of iron or steel, so, if a water-based cleaning agent is used, thoroughly dry all surfaces of the compressor **immediately** after cleaning to avoid rusting.
2. Follow all safety precautions such as use of gloves, eye protection, special clothing, breathing equipment, etc. that are recommended for any cleaning agent being used.
3. Be sure to check all surfaces for sharp edges that could cut skin or damage any safety clothing or apparatus.
4. It is particularly important that all cooling fins be fully cleaned. Dirty cooling fins and other surfaces may result in inadequate cooling and thus create overheating of the compressor that will lead to increased wear and maintenance.

### Maintenance

1. Prior to any maintenance operations, lock out and tag out all electrical power and controls for electrical motor-driven compressor units and all starters and other controls for fuel-powered engine-driven compressor units.
2. Maintenance only to be undertaken by trained personnel.
3. Inspection / access plates are only to be removed once the compressor unit is isolated, depressurized, and immobilized.
4. Adjustment and maintenance operations to be carried out by the end user and the preventive maintenance measures that should be observed are provided in the IOM manual.
5. Maintenance instructions for periodic inspections, indicating parts subject to wear and replacement that can increase vibration and noise hazards etc. are provided in the IOM manual.

### Language

1. The original Declaration of Conformity/Incorporation related to all Corken compressors is in English. Any copy in a language that is not English is a copy of the original.
2. All original Corken Installation, Operation & Maintenance manuals or Important Instruction, including this addendum, are in English and are defined as "ORIGINAL INSTRUCTIONS." Any copy of any of these documents that is not in English is defined as a "TRANSLATION OF THE ORIGINAL INSTRUCTIONS."

*Solutions beyond products...*  
**CORKEN®**

CORKEN, INC. • A Unit of IDEX Corporation

9201 North I-35 Service Road, Oklahoma City, OK. 73131

Phone (405) 946-5576 • Fax (405) 948-7343

Website: [www.corken.com](http://www.corken.com)

E-mail: [cocsalesdept@idexcorp.com](mailto:cocsalesdept@idexcorp.com)



[@CorkenInc](https://twitter.com/CorkenInc)

