

# IMPORTANT INSTRUCTIONS

For: 2438-X Suction Valve Assembly  
2532-1X Suction Specification 3

2439-X Discharge Valve Assembly  
2618-X Unloader Assembly

## COMPRESSOR TYPES 391, 491, 791 (2ND STAGE)

Each valve assembly is easily removable as a unit for inspection. If a valve disc or spring is broken, the valve assembly should be replaced. To order replacement parts, consult your Corken Service Manual, Section E, for the correct part numbers and always include the compressor **model and serial numbers** on your order. Complete valve assembly replacement is recommended when repair is necessary.

The following instructions show the various assemblies used on different compressor models.

Since several suction valve arrangements are available on each compressor, it is necessary to know your model number and identify the following valve type specification number.

If the valve was leaking due to dirt or other contamination which kept the disc and seat from sealing, the valve may be cleaned and reused. New gaskets should be used to assure a good seal.

EXAMPLE: Model No.	D391AM	3	FBANSNN
	D491AM	8	FBABSNN
	D791JM	78	FBAFSNN
Valve Type Spec.	_____		

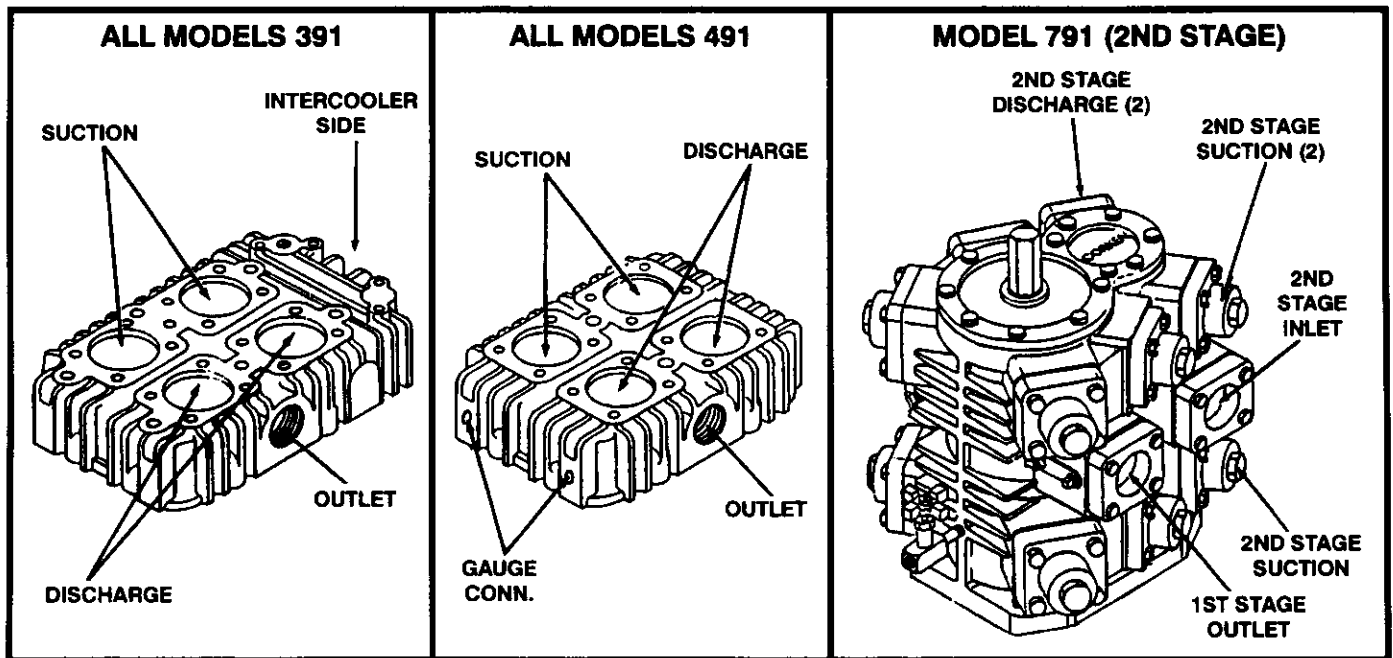

*Solutions beyond products...*



9201 North I-35 Service Road • Oklahoma City, OK 73131  
Phone: 405.946.5576 • Fax: 405.948.7343  
Website: [www.corken.com](http://www.corken.com) • E-mail: [cocsalesdept@idexcorp.com](mailto:cocsalesdept@idexcorp.com)

**CAUTION: Always Relieve Pressure in the Unit Before Attempting Any Repairs.**

1. Unscrew the valve cap or unloader cap.
2. Remove holddown screw using special Corken wrench.
3. Remove valve cover plate.
4. The valve assembly can now be lifted out.
5. Inspect for dirt or broken parts.
6. Clean or replace with a new valve assembly.

7. Replace valve cover plate. Torque bolts to 35-37 ft.-lbs. **CAUTION:** Be sure the holddown screw has been removed.
8. Tighten the holddown screw (40 ft.-lbs.). **NOTE:** Gaskets and o-rings are not normally reusable.
9. Replace valve cap. Tighten to 25 ft.-lbs. (40 ft.-lbs. for valve cap with a **metal** gasket).

**NOTE:** Check bolts and valve holddown screws after first week of operation. Retorque if necessary.

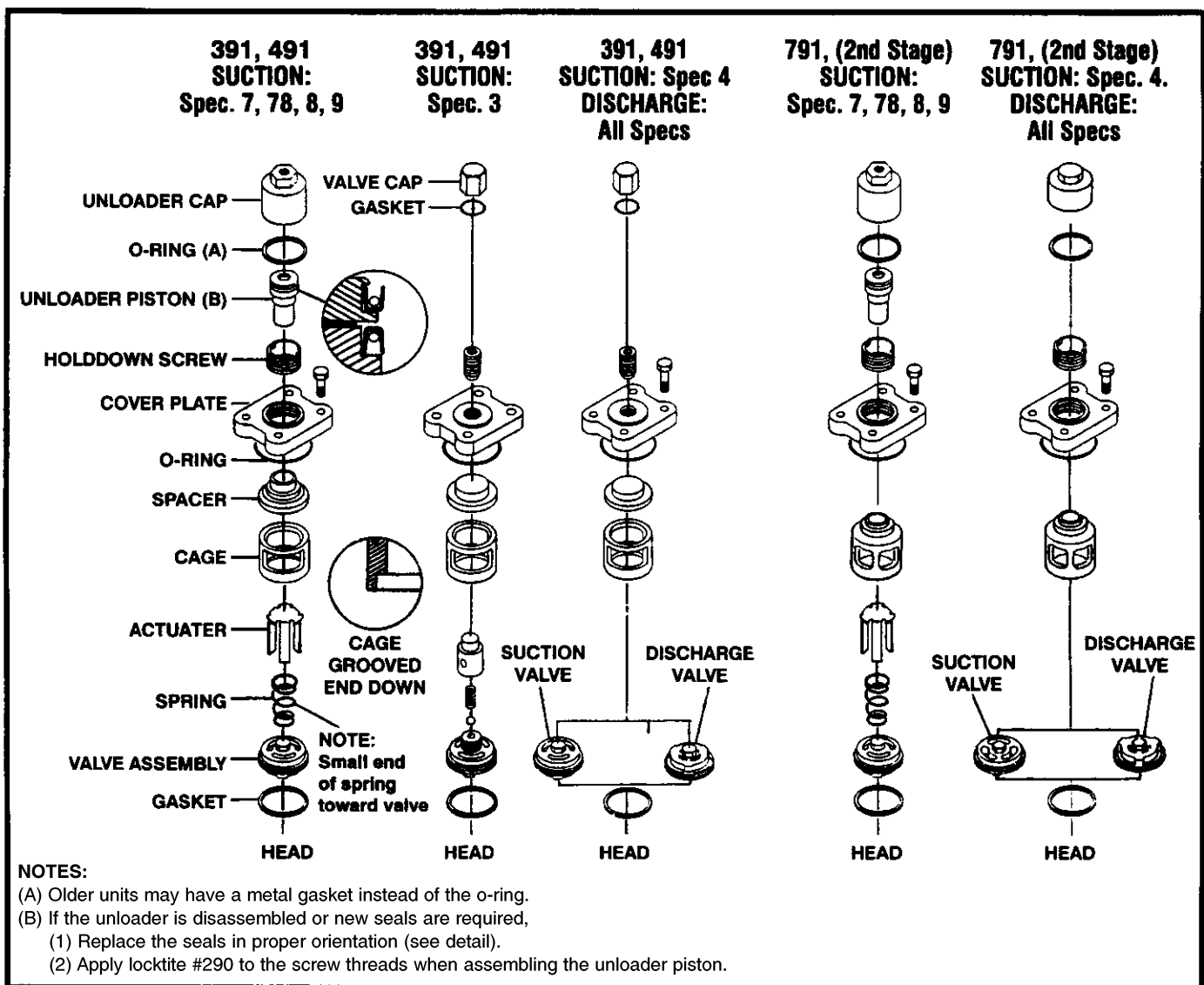

Warning: (1) Periodic inspection and maintenance of Corken products is essential. (2) Inspection, maintenance and installation of Corken products must be made only by experienced, trained and qualified personnel. (3) Maintenance, use and installation of Corken products must comply with Corken instructions, applicable laws and safety standards (such as NFPA Pamphlet 58 for LP-Gas and ANSI K61.1-1989 for Anhydrous Ammonia). (4) Transfer of toxic, dangerous, flammable or explosive substances using Corken products is at user's risk, and equipment should be operated only by qualified personnel according to applicable laws and safety standards.